

Introduction to Vacuum Pumps, Applications, Future Changes & Development Trends.

Coventry, 19th October 2011
Clive Tunna

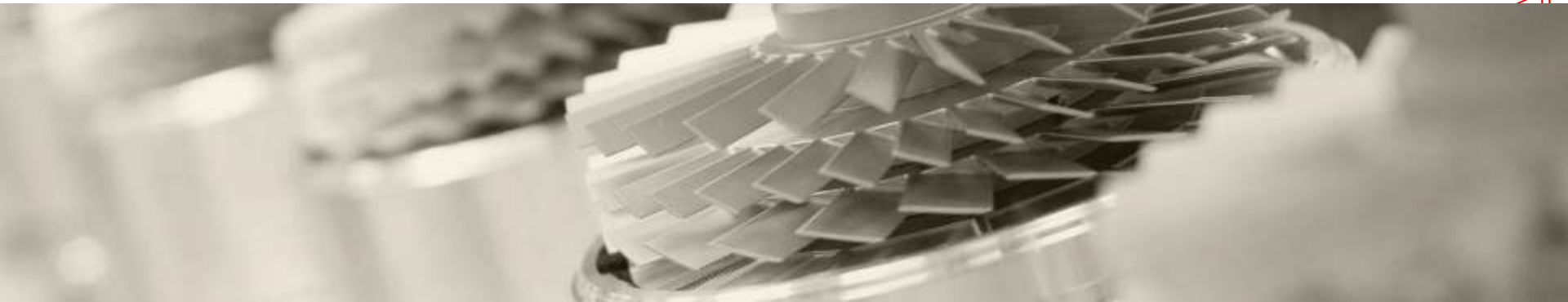

- 1** Vacuum family tree
- 2** Fore vacuum mechanisms – pressure & speed range
- 3** High vacuum mechanisms – pressure & speed range
- 4** Fore vacuum pump applications
- 5** High vacuum pump applications
- 6** Future developments

- 1** Vacuum family tree
- 2 Fore vacuum mechanisms – pressure & speed range
- 3 High vacuum mechanisms – pressure & speed range
- 4 Fore vacuum pump applications
- 5 High vacuum pump applications
- 6 Future developments

Vacuum Pumps

Vacuum pumps
(Operating principle)

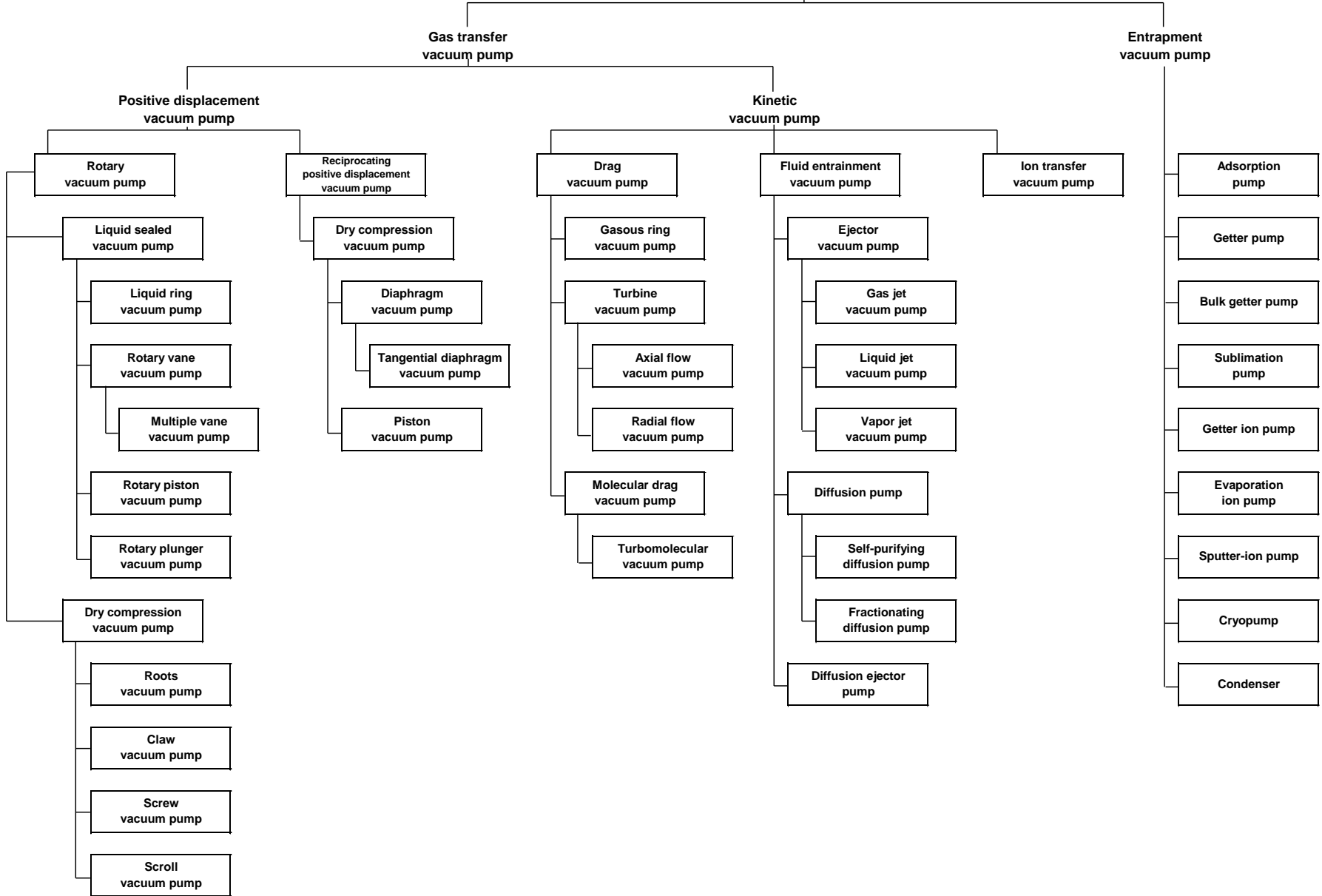

Vacuum Pumps

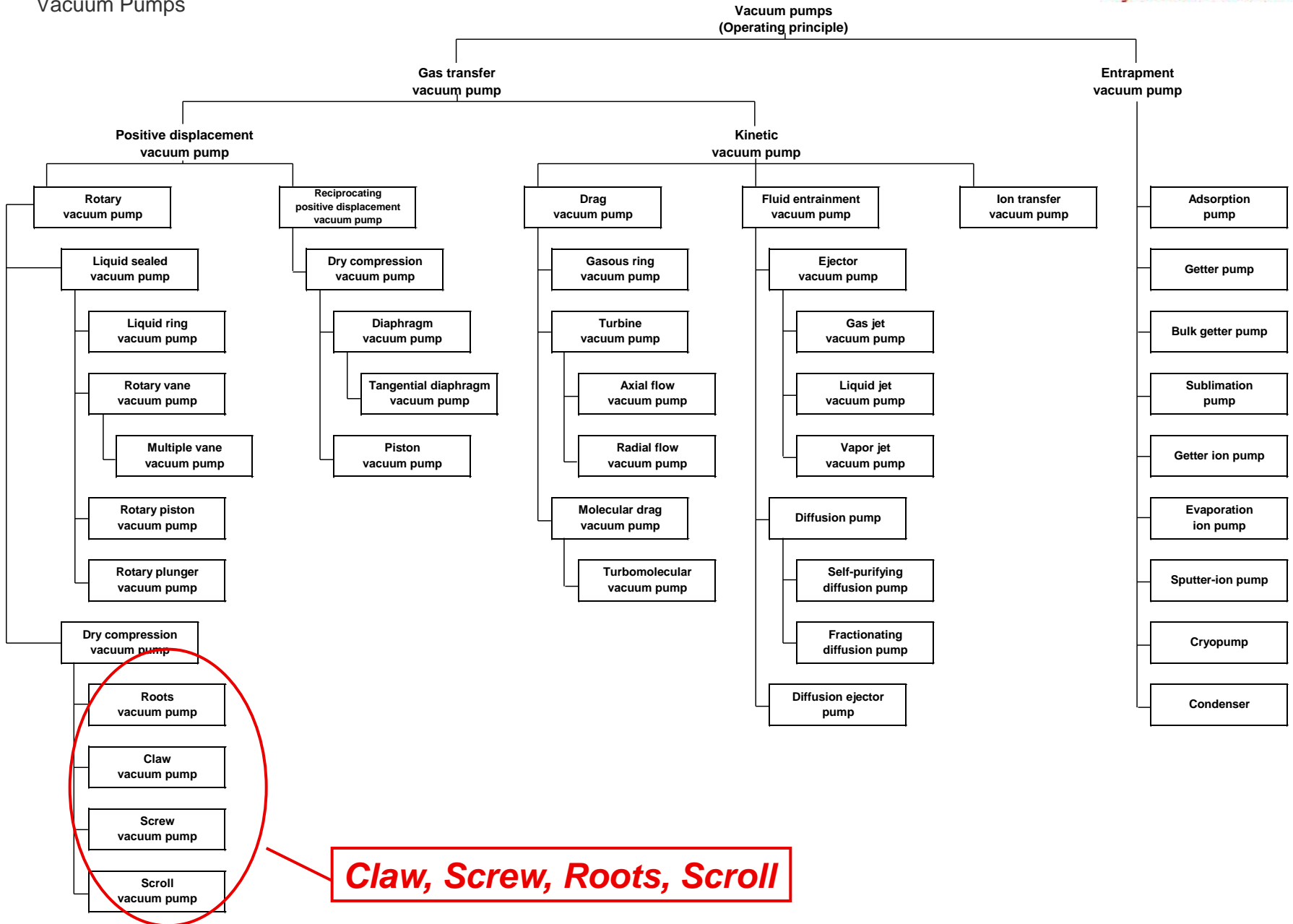

Vacuum Pumps

Vacuum pumps
(Operating principle)

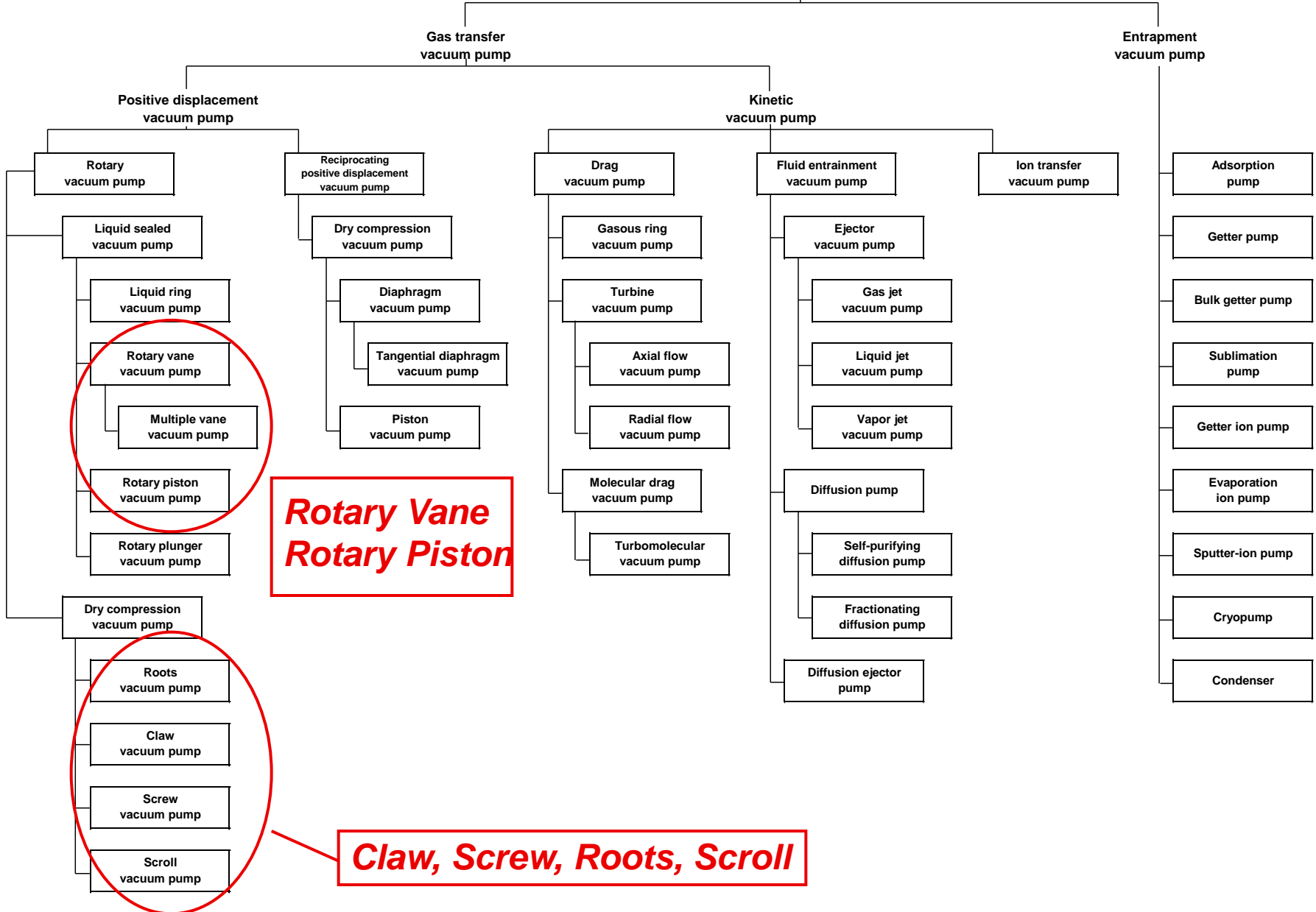

**Rotary Vane
Rotary Piston**

Claw, Screw, Roots, Scroll

Vacuum Pumps

Vacuum pumps
(Operating principle)

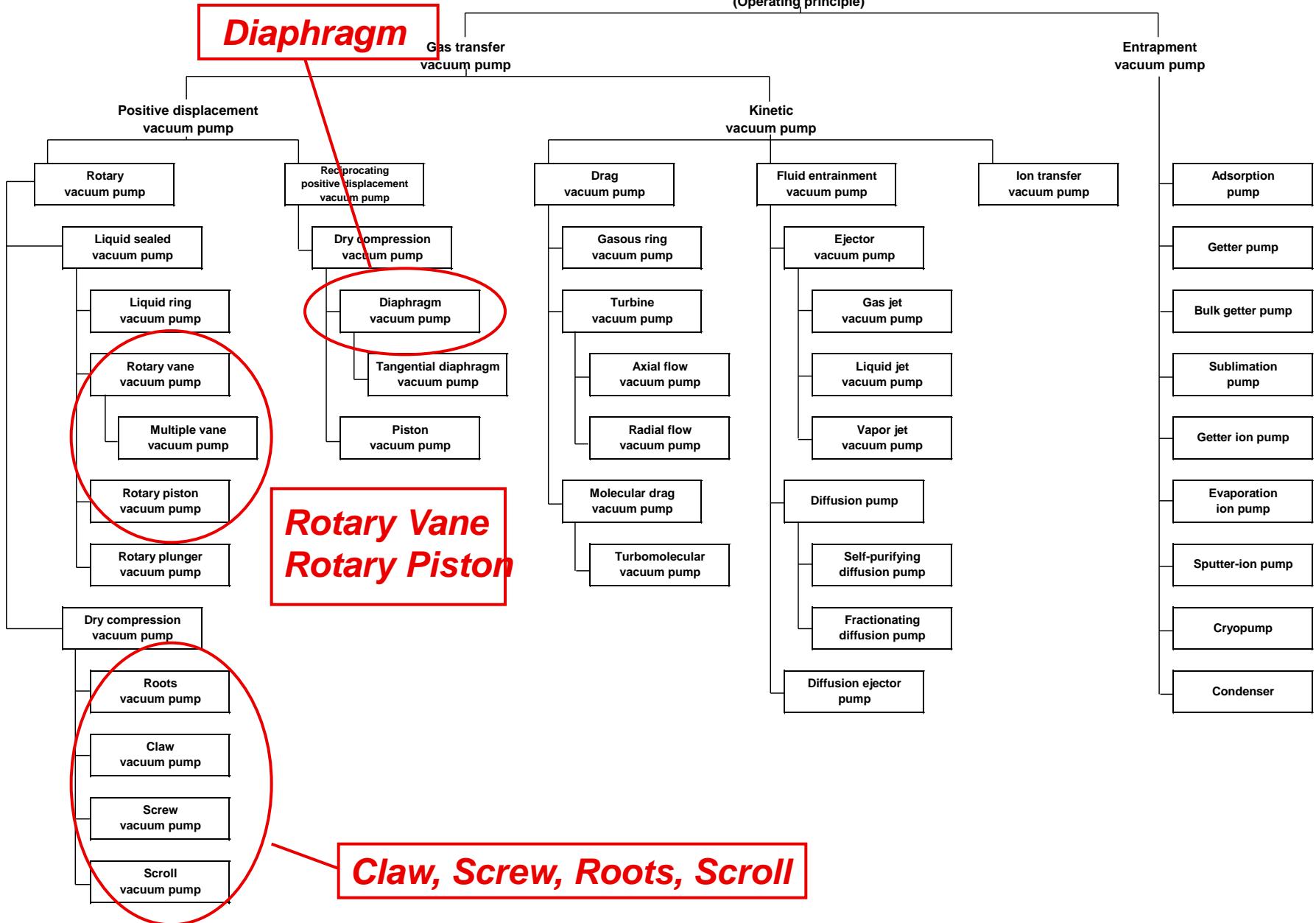

Vacuum Pumps

Vacuum pumps
(Operating principle)

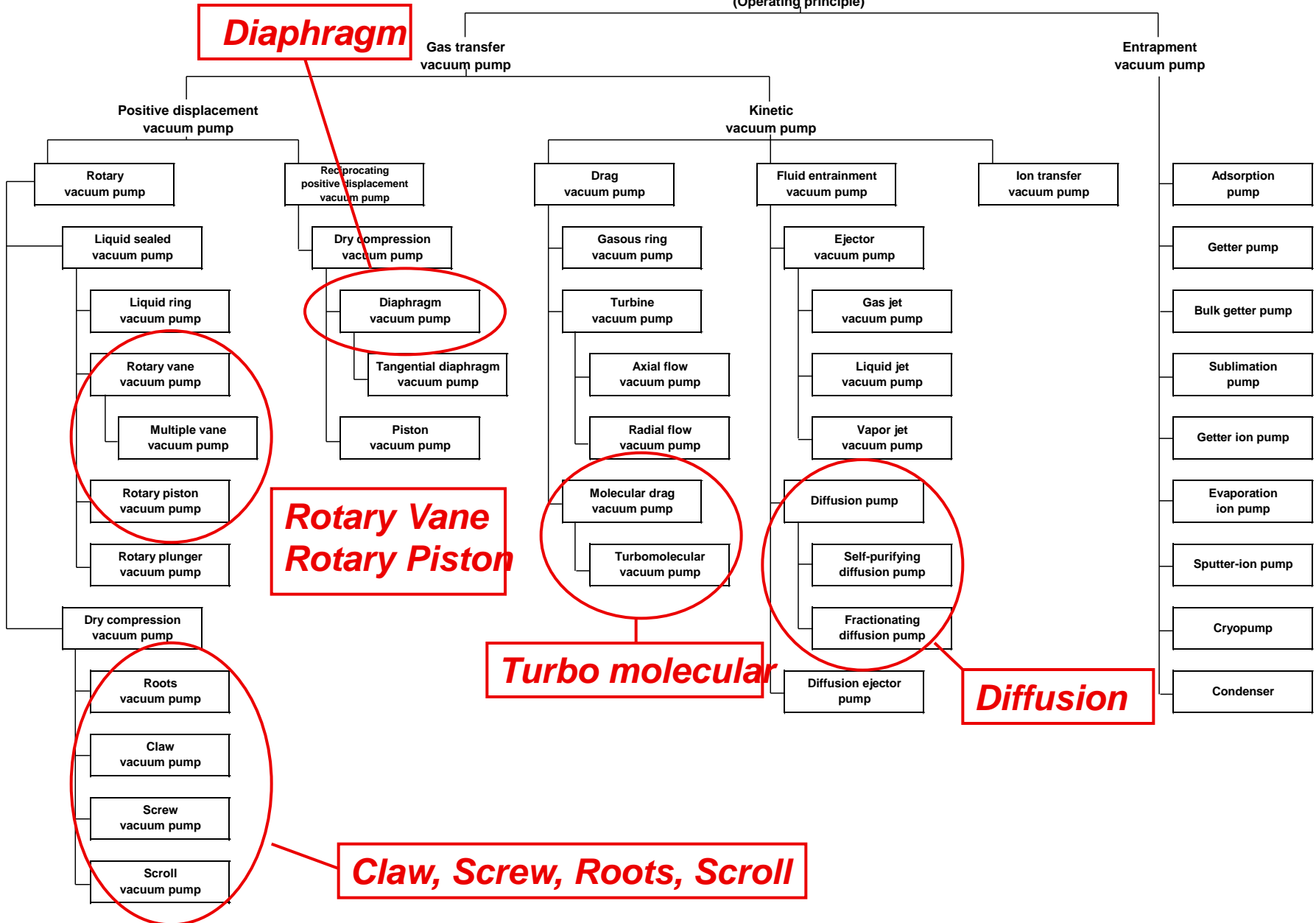

- 1 Vacuum family tree
- 2 Fore vacuum mechanisms – pressure & speed range**
- 3 High vacuum mechanisms – pressure & speed range
- 4 Fore vacuum pump applications
- 5 High vacuum pump applications
- 6 Future developments

Pumping speed vs. Pressure range

Fore Vacuum pumps

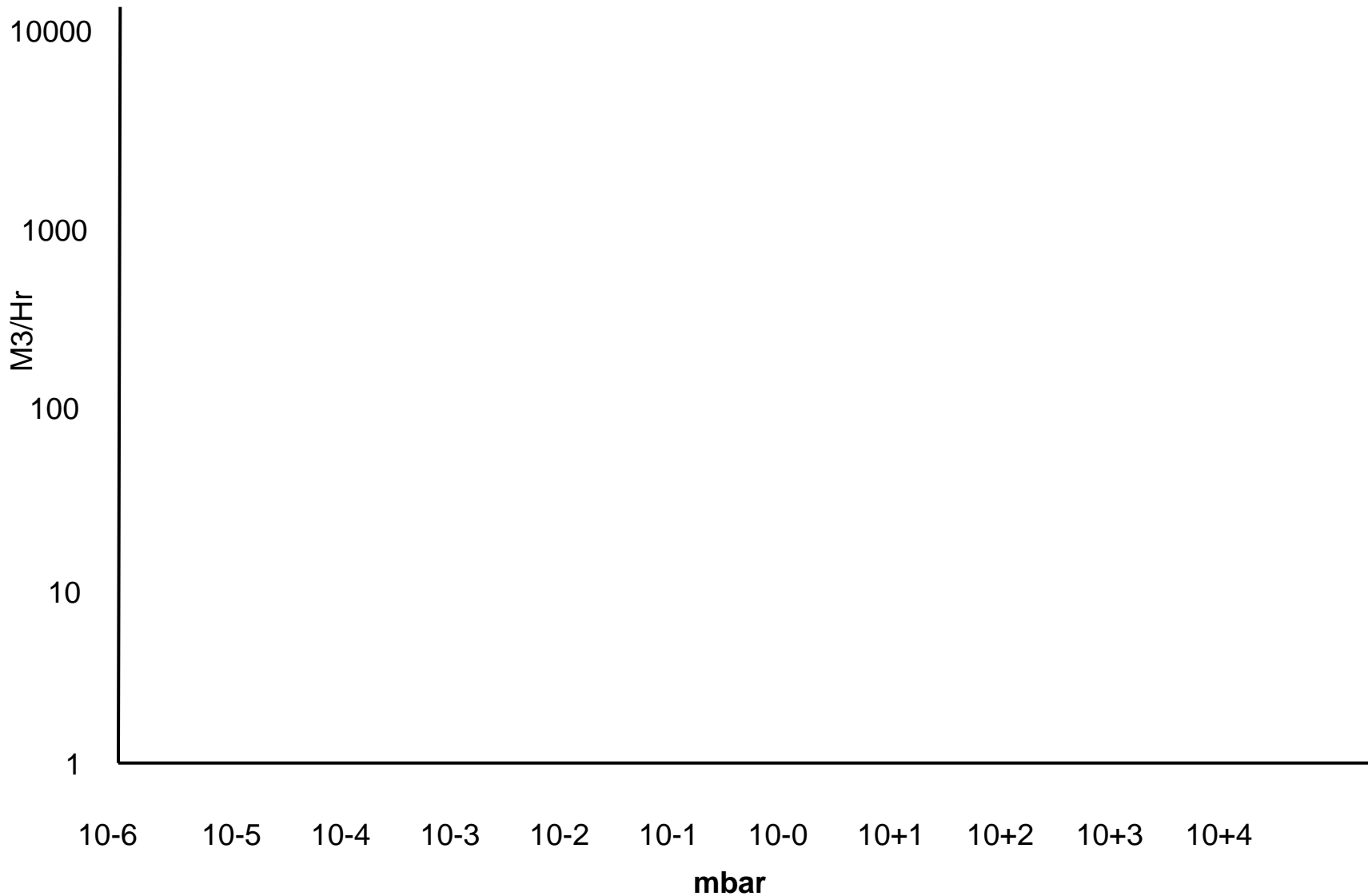

Pumping speed vs Pressure range Fore Vacuum pumps

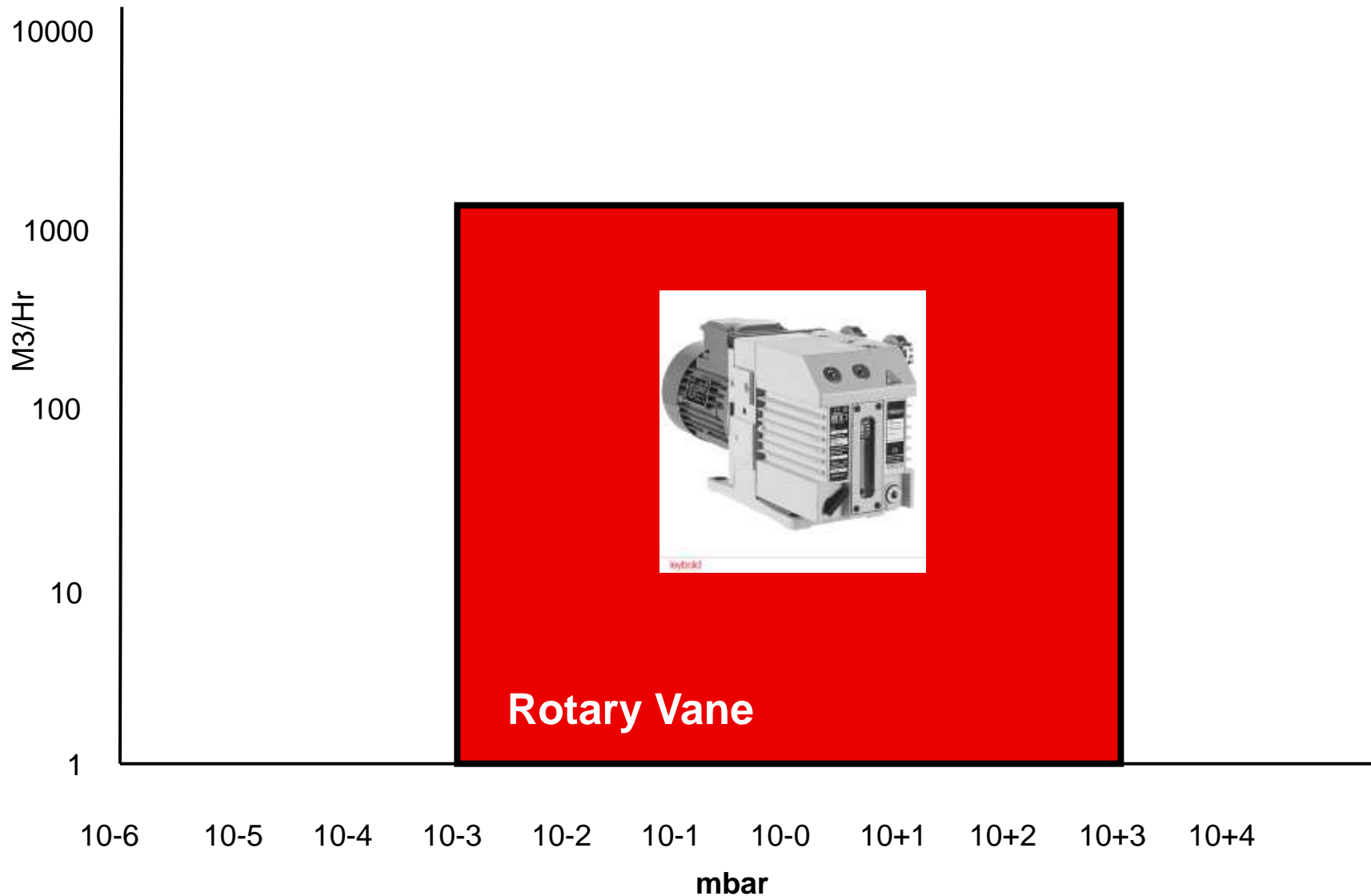

Pumping speed vs Pressure range

Fore Vacuum pumps

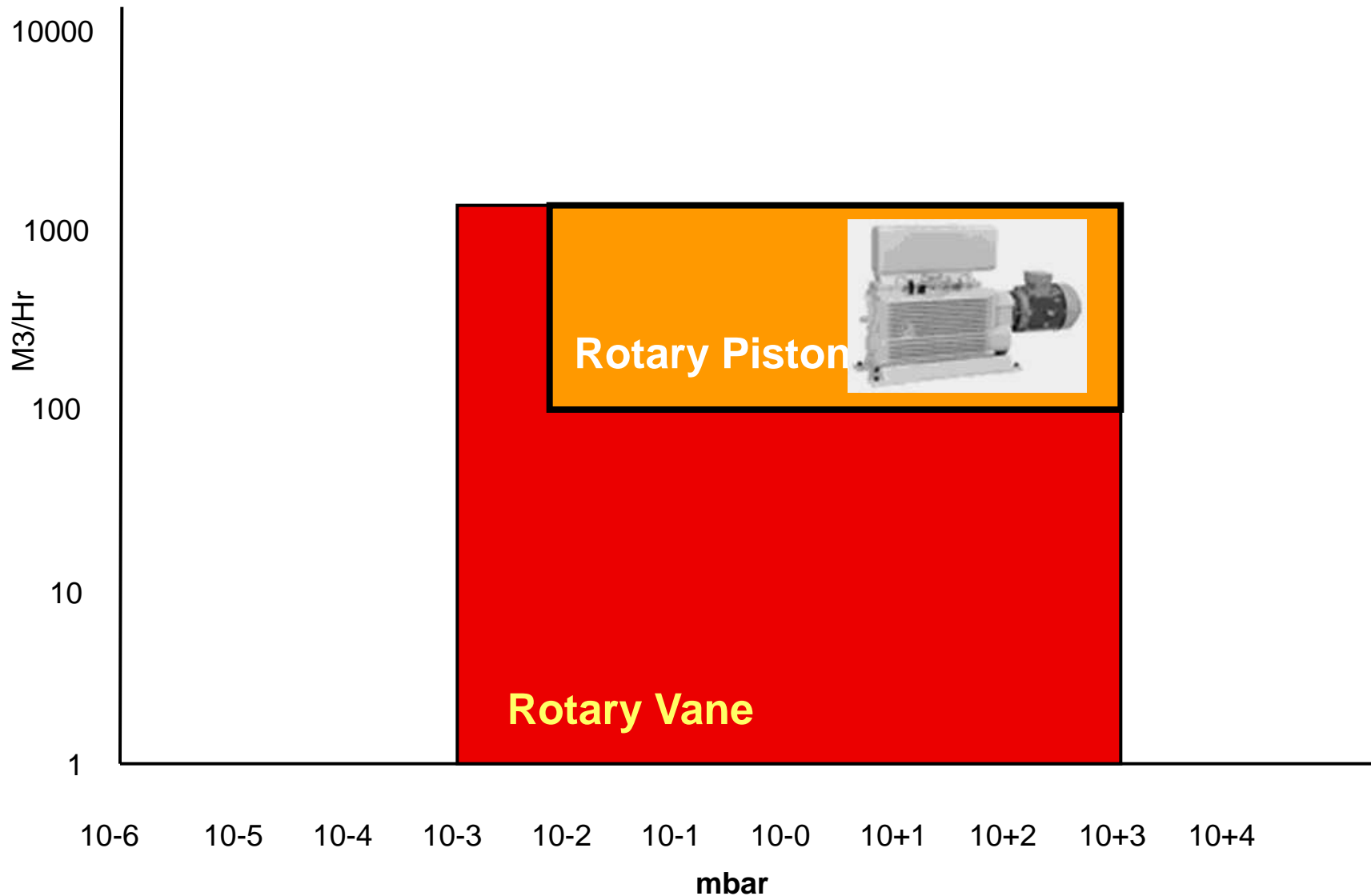

Pumping speed vs Pressure range Fore Vacuum pumps

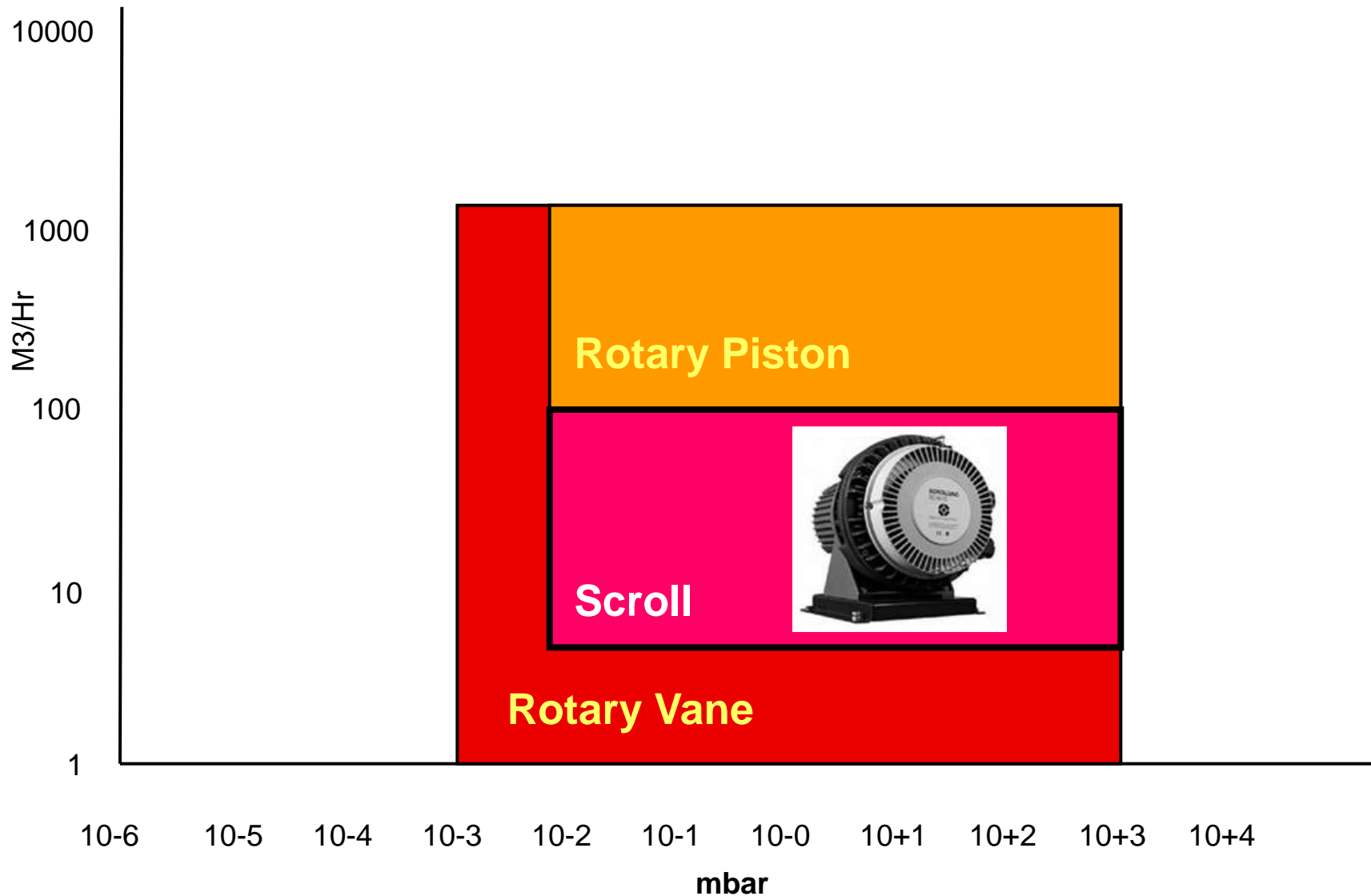

Pumping speed vs Pressure range

Fore Vacuum pumps

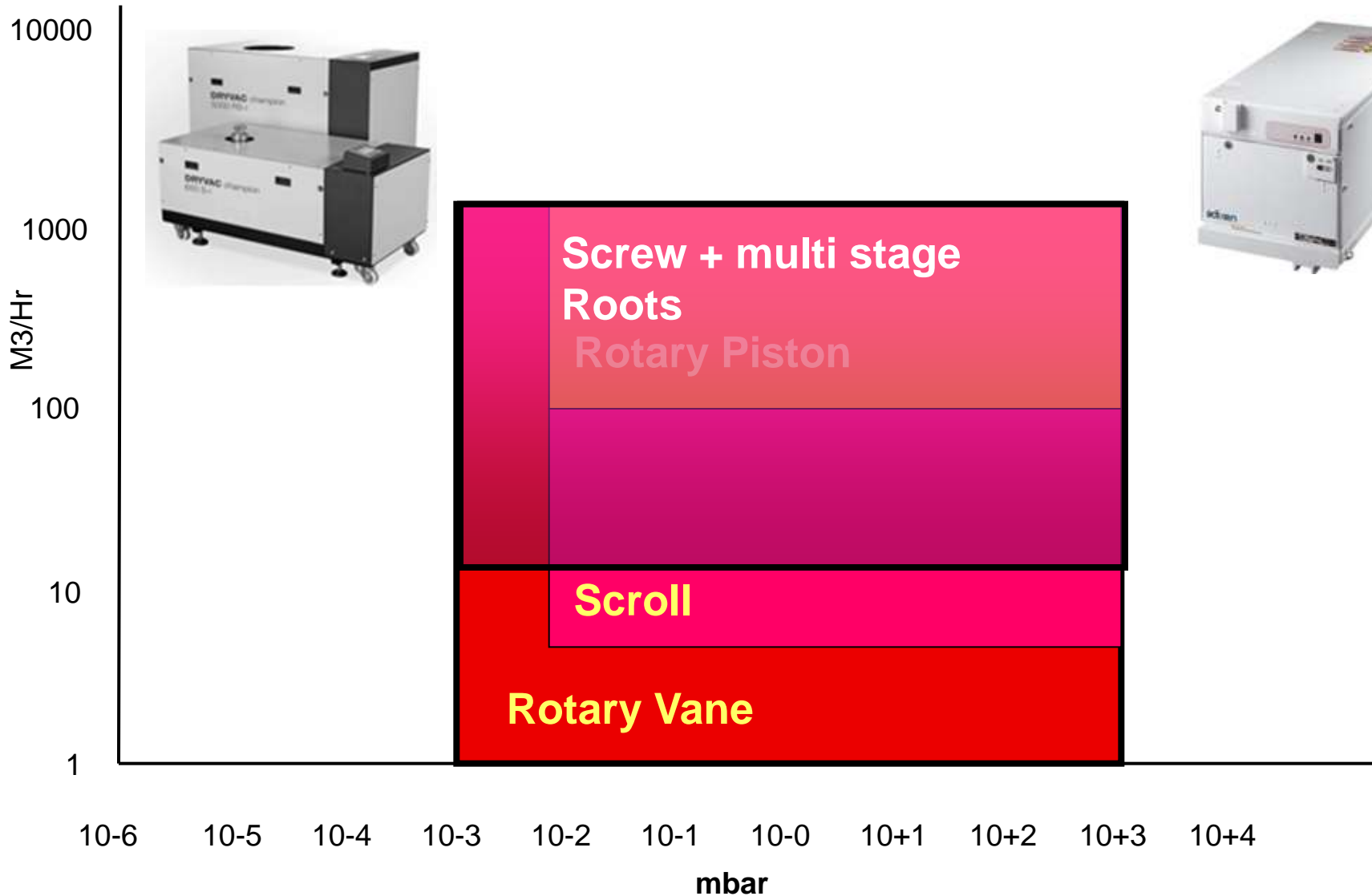

Pumping speed vs Pressure range Fore Vacuum pumps

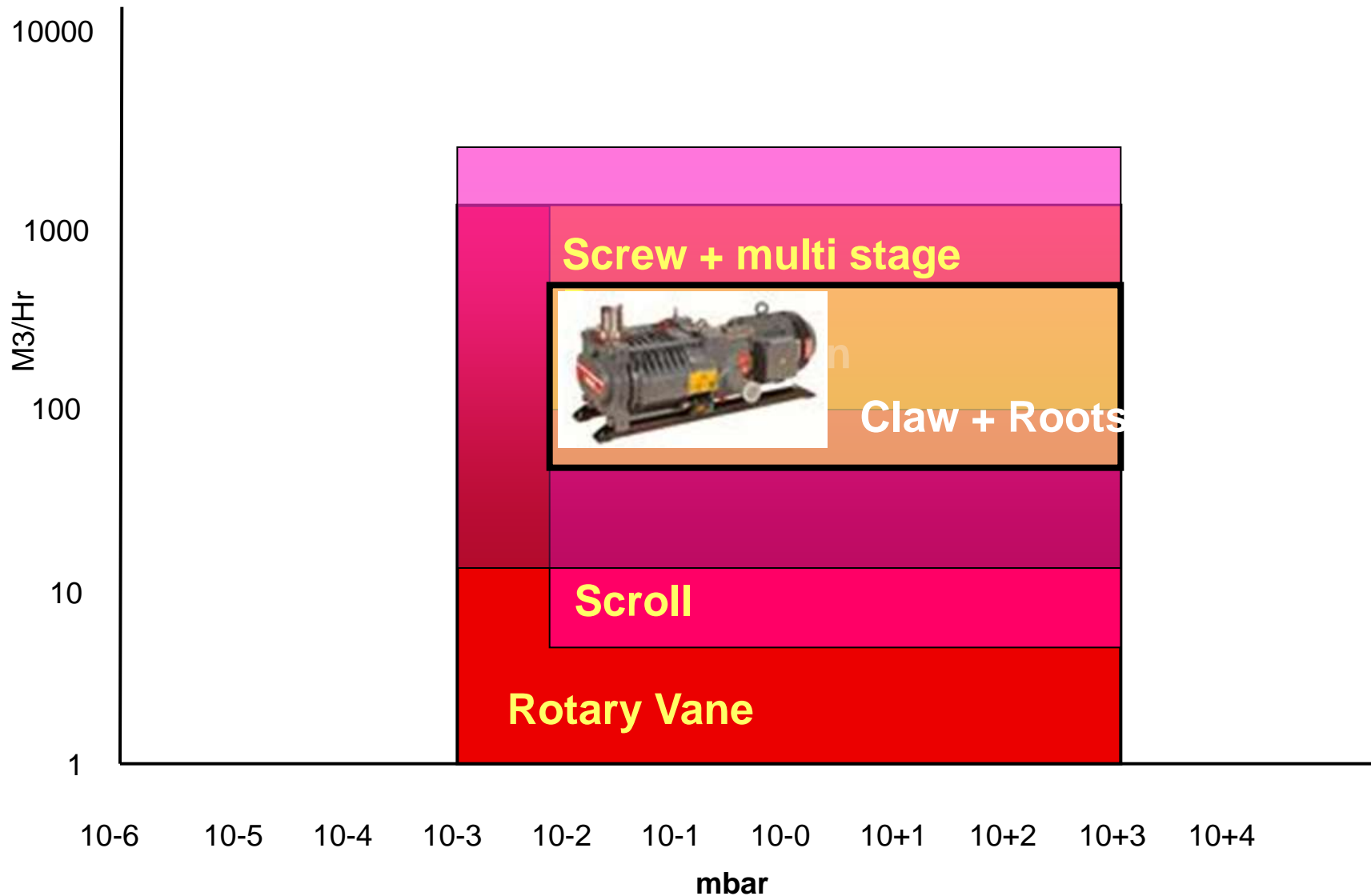

Pumping speed vs Pressure range

Fore Vacuum pumps

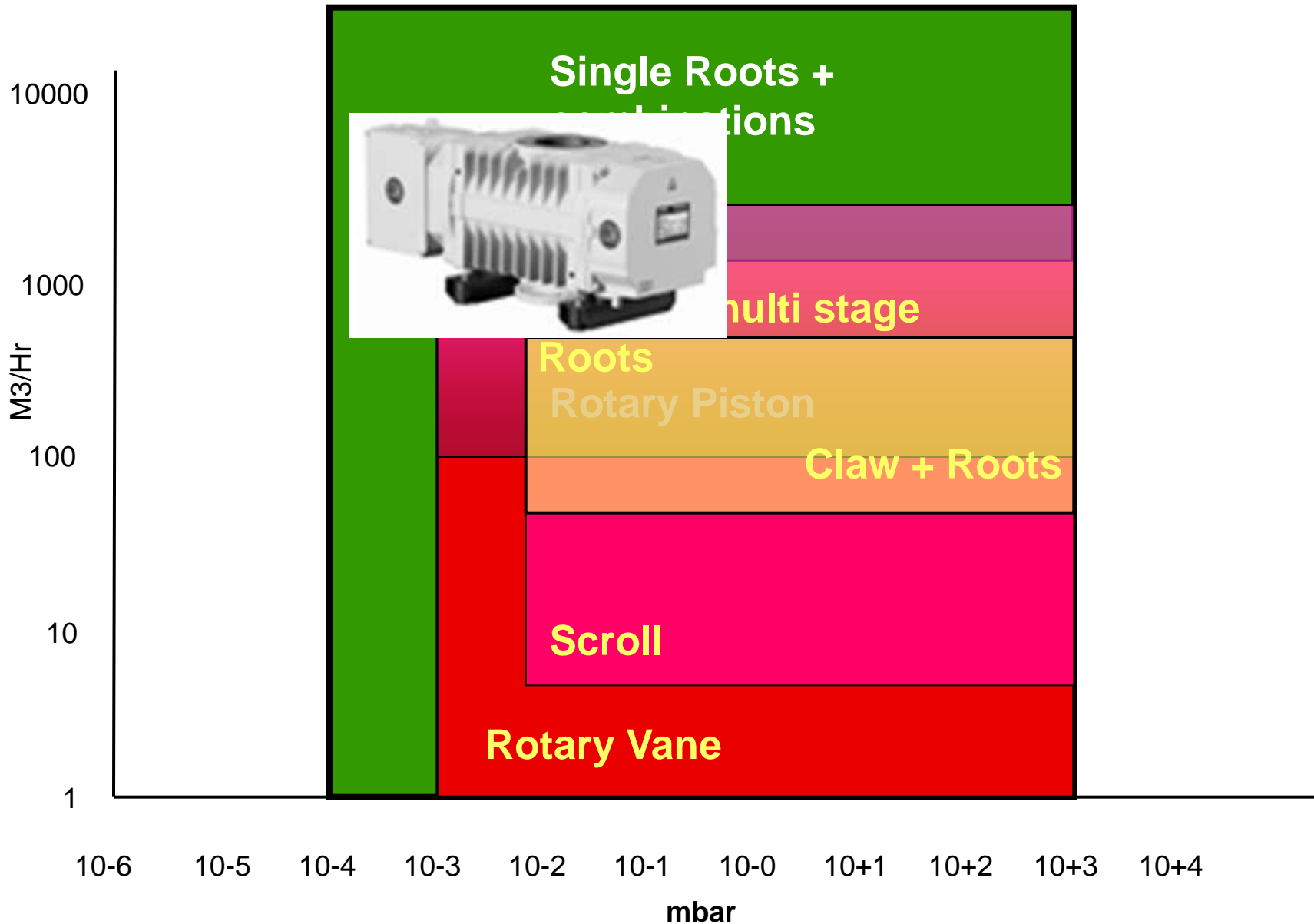

Nachdruck, auch auszugsweise, verboten
Proprietary & Confidential / © by Oerlikon Leybold Vacuum

Pumping speed vs Pressure range

Fore Vacuum pumps

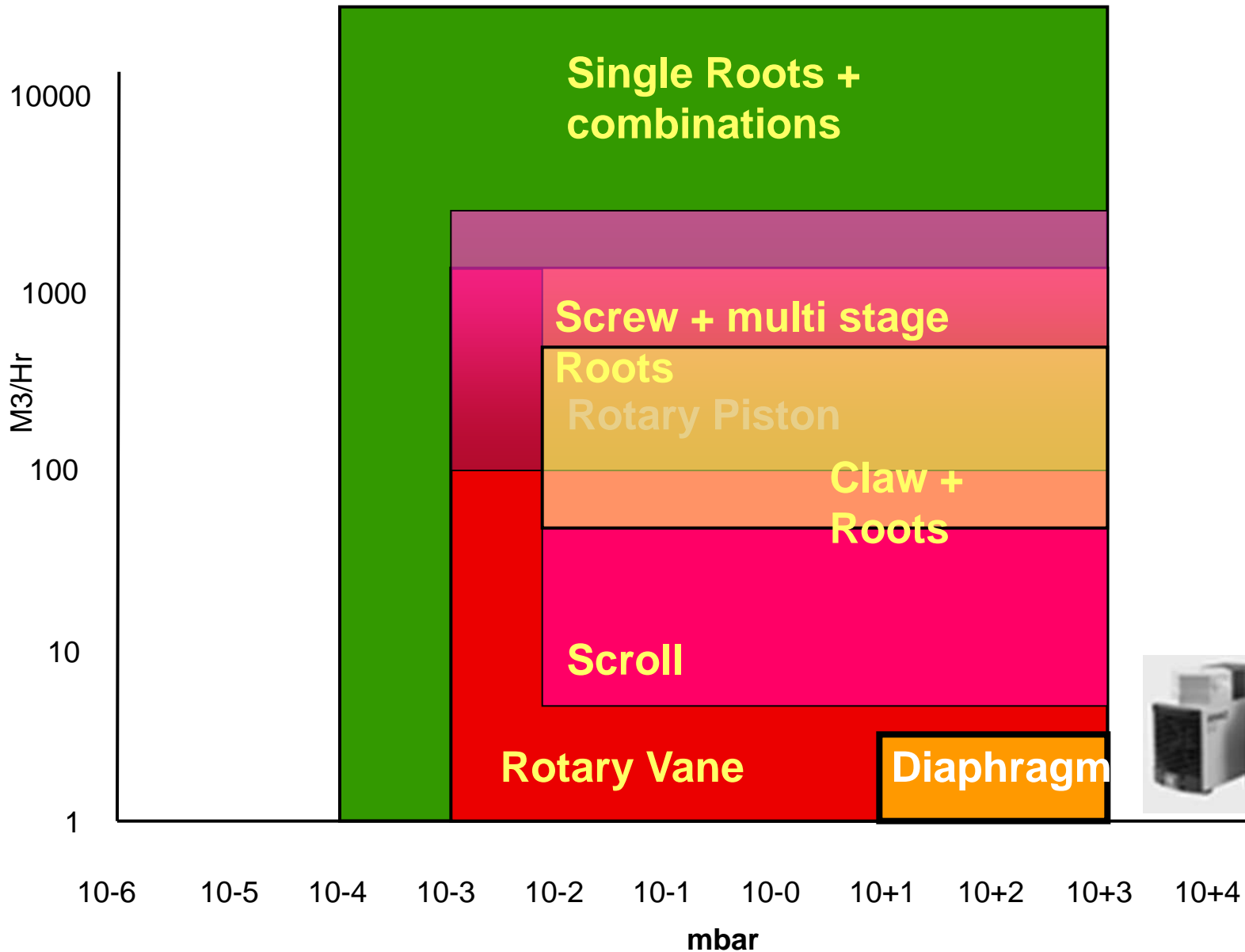

- 1 Vacuum family tree
- 2 Fore vacuum mechanisms – pressure & speed range
- 3 High vacuum mechanisms – pressure & speed range**
- 4 Fore vacuum pump applications
- 5 High vacuum pump applications
- 6 Future developments

Pumping speed vs Pressure range

High Vacuum pumps

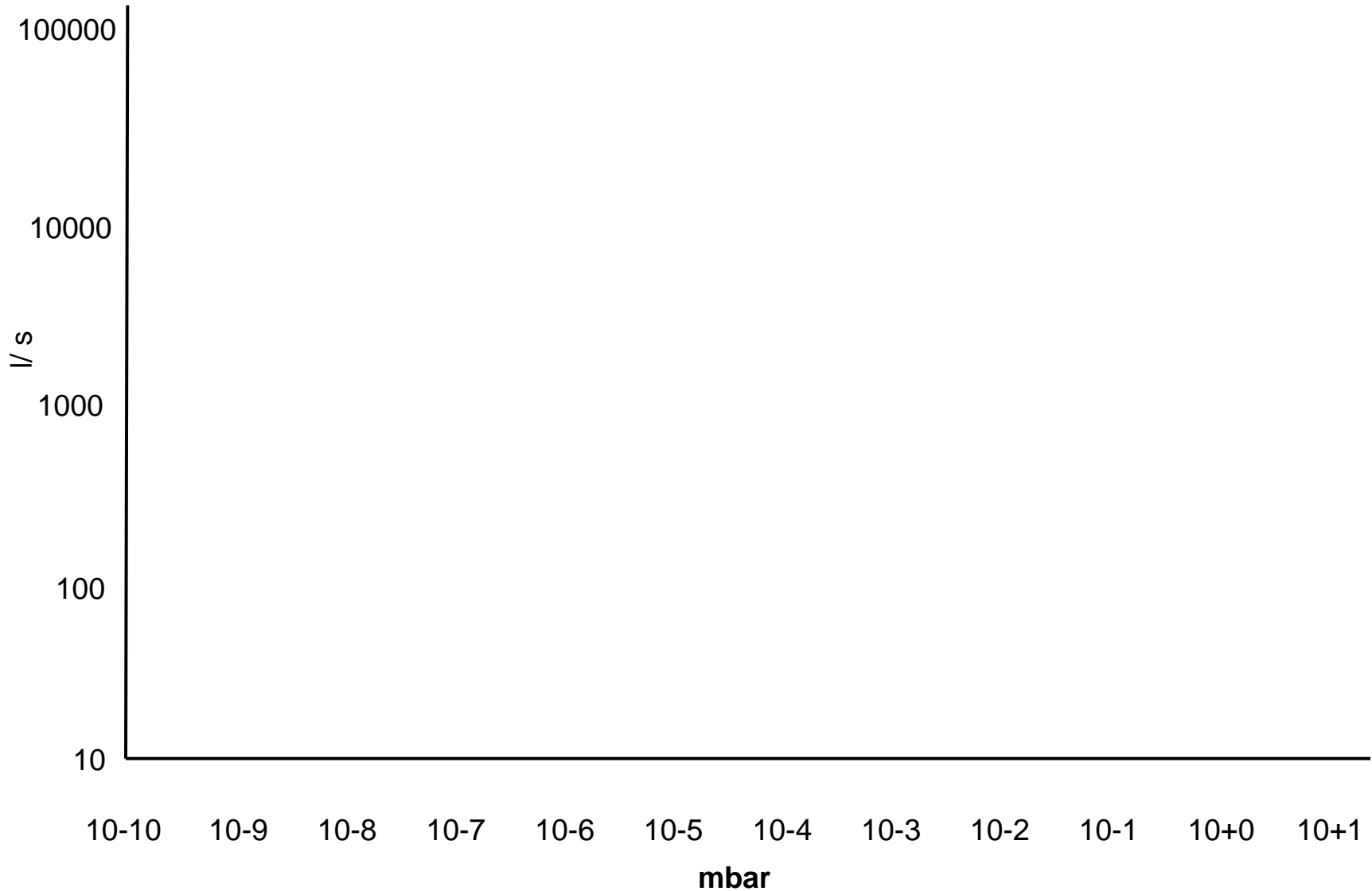

Pumping speed vs Pressure range

High Vacuum pumps

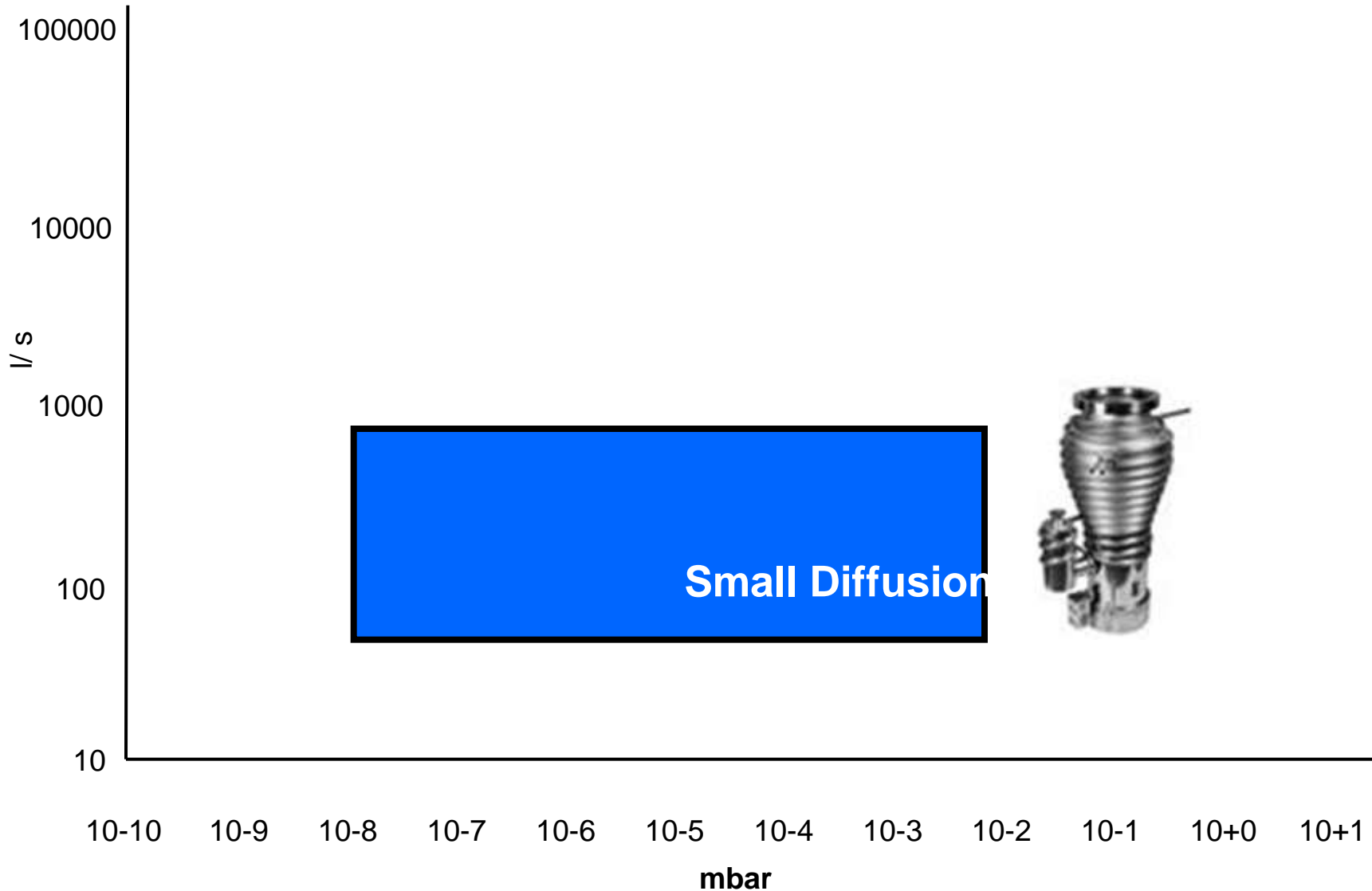

Pumping speed vs Pressure range

High Vacuum pumps

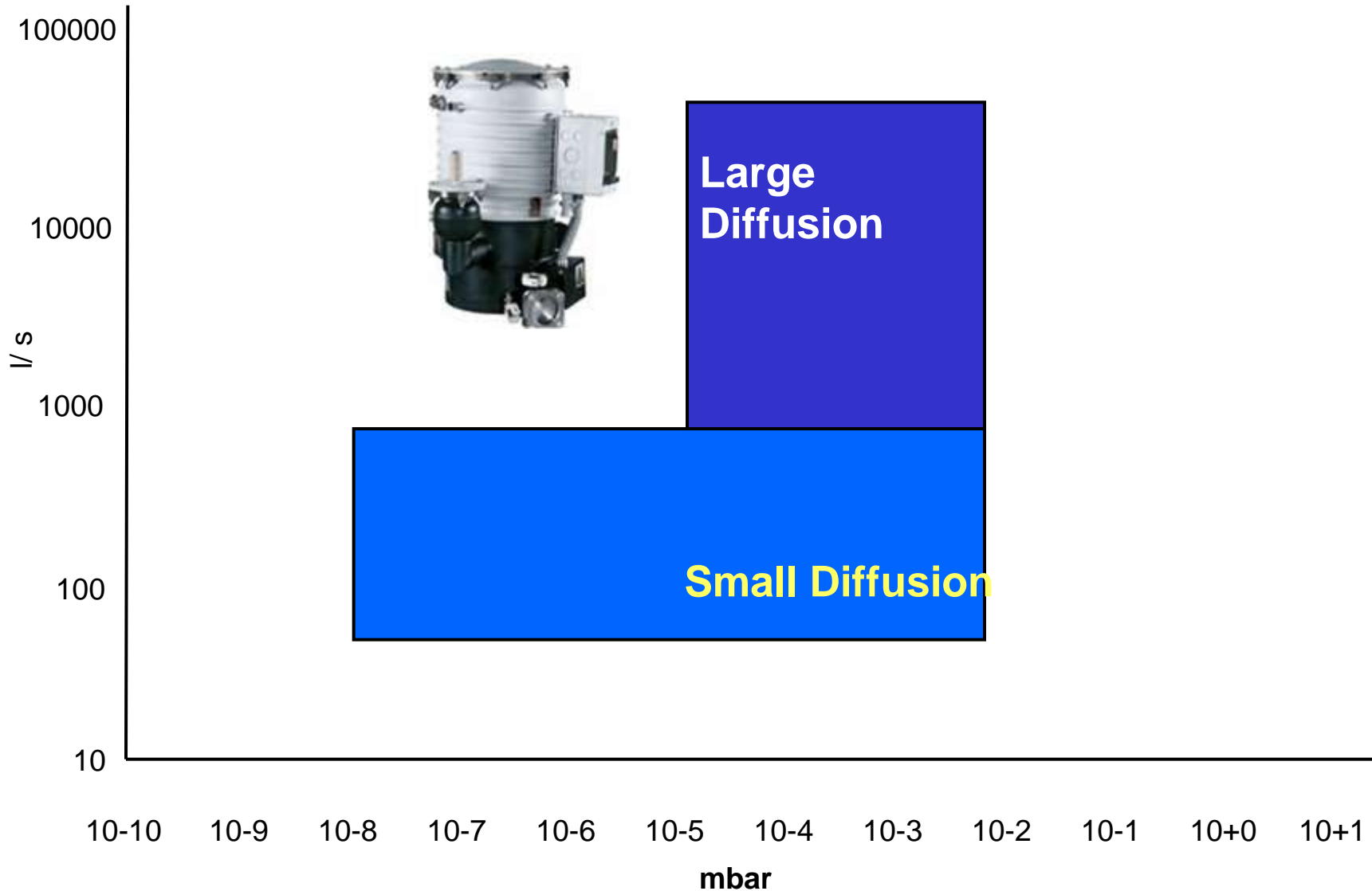

Pumping speed vs Pressure range

High Vacuum pumps

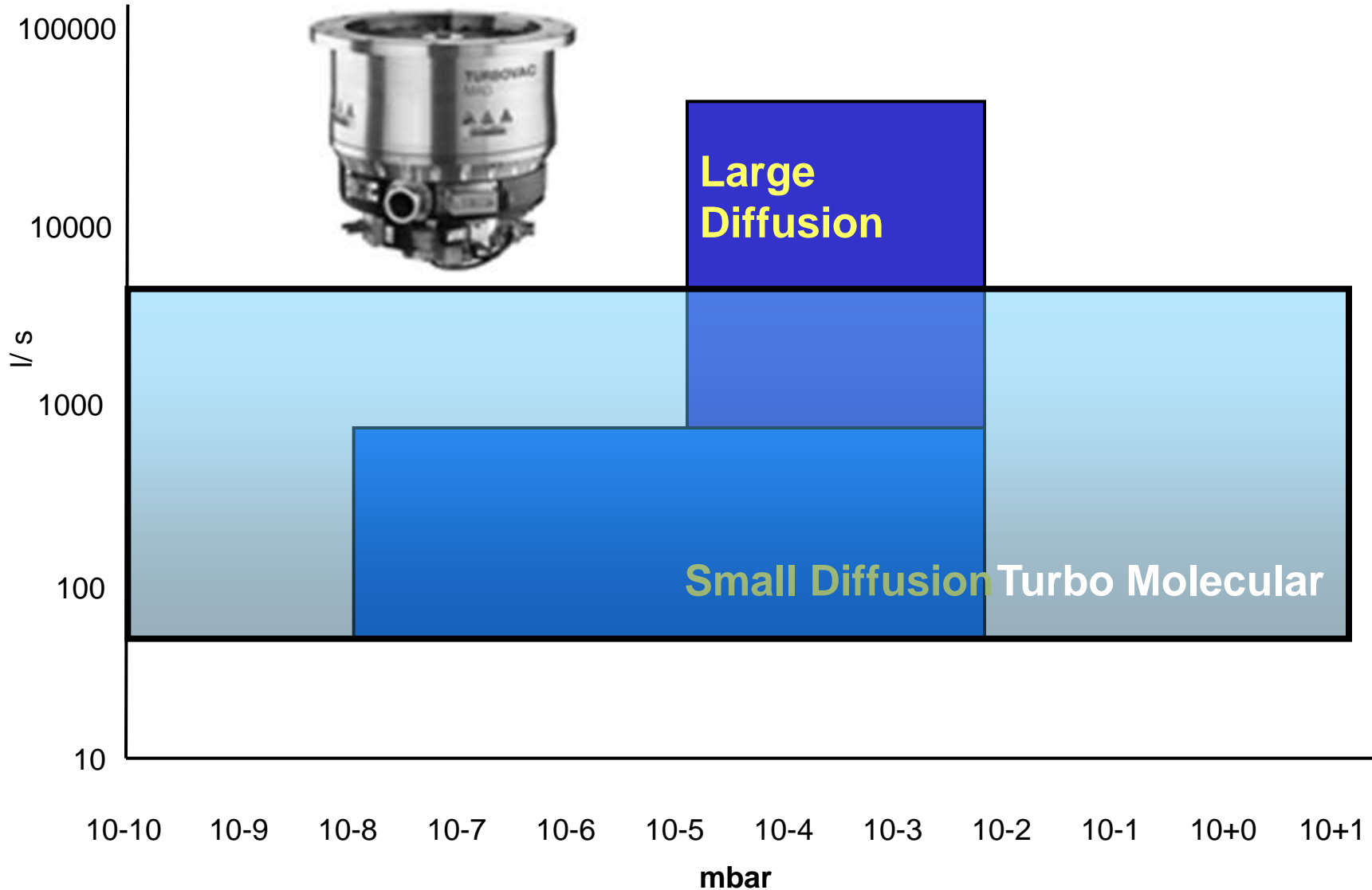

Pumping speed vs Pressure range

High Vacuum pumps

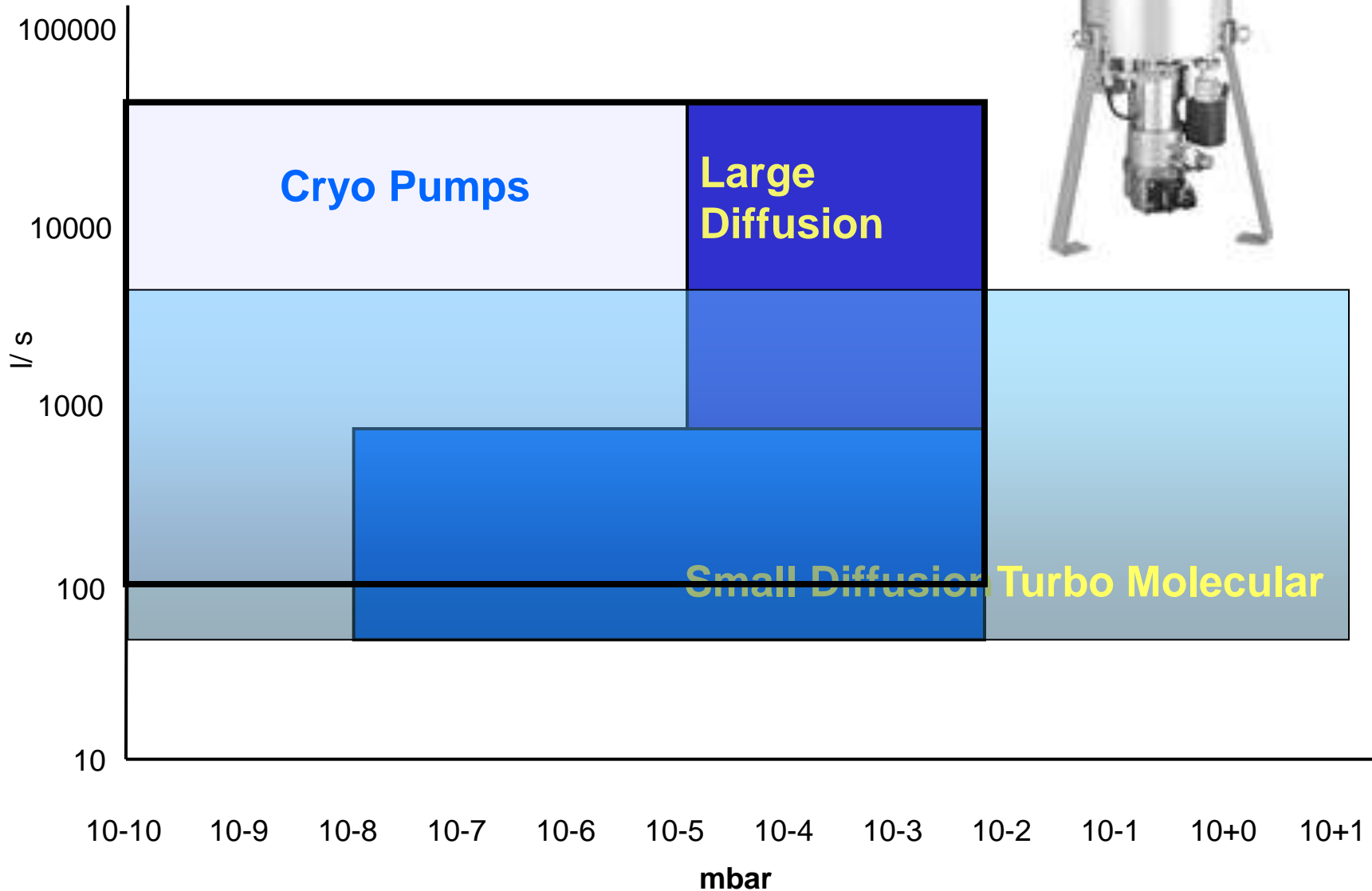

- 1 Vacuum family tree
- 2 Fore vacuum mechanisms – pressure & speed range
- 3 High vacuum mechanisms – pressure & speed range
- 4 Fore vacuum pump applications**
- 5 High vacuum pump applications
- 6 Future developments

Fore Vacuum

- Air
- Inert gas
- Helium / Hydrogen
- Flammables
- Pyrophoric
- Corrosive
- Radioactive
- Toxic
- Vapours
- Hot gases
- Dusts
- Sticky deposits

High Vacuum

- Air
- Inert gas
- Helium / Hydrogen
- Flammables
- Corrosives
- Toxic
- Vapours

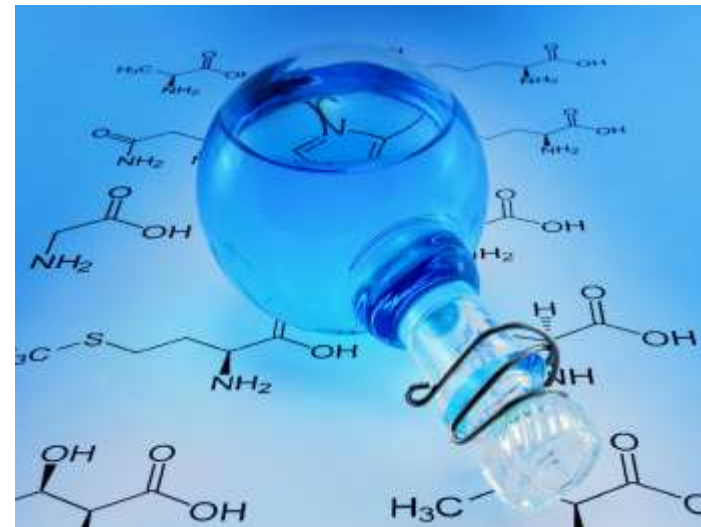

Screw dry pump

Gas throughput

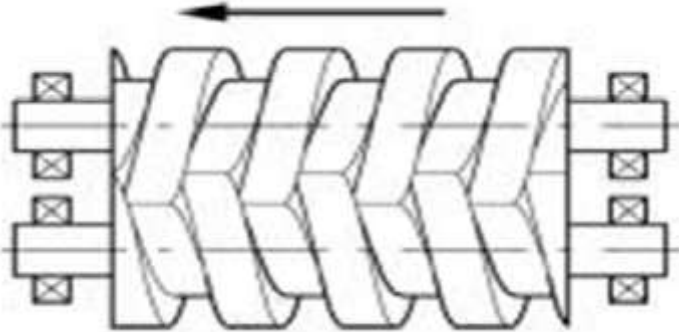

USP: Robustness on harsh duties
Hydrocarbon free.
Low power consumption.

Cost: High

Negative: Needs seal purge gas

Pumping speed range:

100 m³/hr > 2500 m³/hr

End pressure:

10-3 mbar

Applications:

- | | |
|-----------------------|-----|
| - Air | yes |
| - Inert gases | yes |
| - He / H ₂ | yes |
| - Flammable | yes |
| - Pyrophoric | yes |
| - Reactive | yes |
| - Radioactive | yes |
| - Toxic | yes |
| - Vapours | yes |
| - Hot gases | yes |
| - Dust | yes |
| - Sticky deposits | yes |

[with precautions]



Scroll dry pump

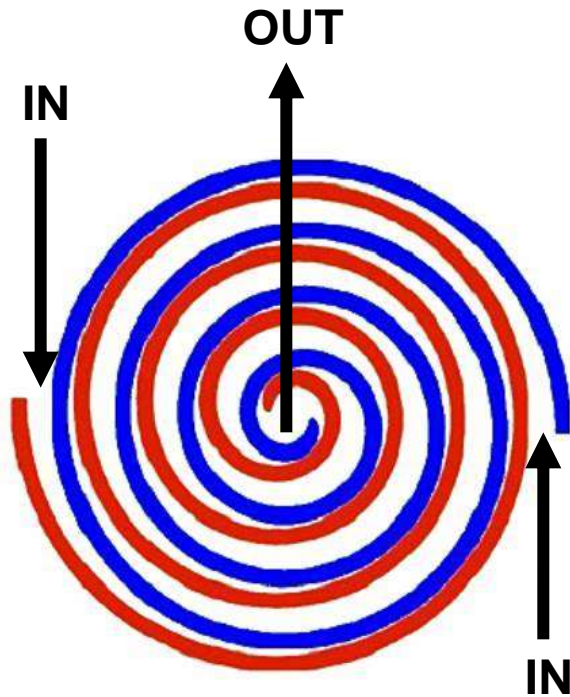

USP: Hydrocarbon free

Cost: High

Negative: Yearly tip seal change

Pumping speed range:
5 m³/hr > 100 m³/hr

End pressure:
10-2 mbar

Applications:

- | | |
|-----------------------|----------------|
| - Air | yes |
| - Inert gases | yes |
| - He / H ₂ | poor |
| - Flammable | with dilution |
| - Pyrophoric | no |
| - Reactive | no |
| - Radioactive | no |
| - [Special pump only] | |
| - Toxic | no |
| - [Special pump only] | |
| - Vapours | no condensable |
| - Hot gases | no |
| - Dust | no |
| - Sticky deposits | no |



Claw dry pump

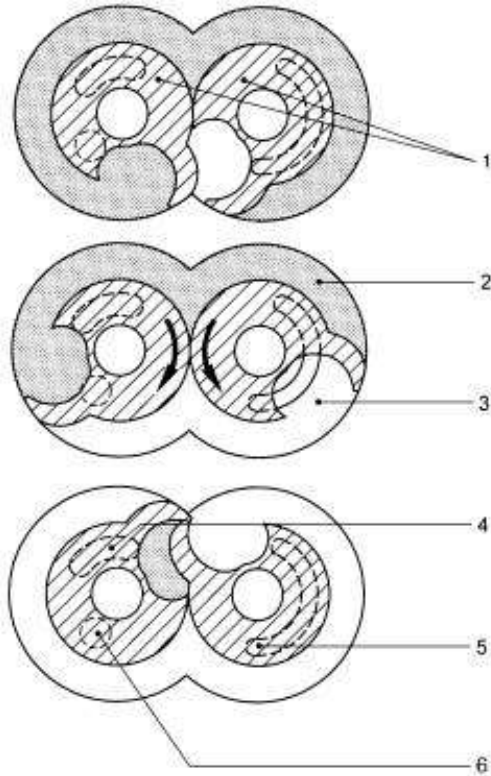

USP: Robustness on harsh duties
Hydrocarbon free

Cost: High

Negative: Re-start problems

Pumping speed range:
80 m³/hr > 400 m³/hr

End pressure:
10⁻² mbar – 10 mbar

Applications:

- Air yes
- Inert gases yes
- He / H₂ yes
- Flammable yes
- Pyrophoric yes
- Reactive yes
- Radioactive yes
- Toxic yes
- Vapours yes
- Hot gases yes
- Dust yes
- [with precautions]
- Sticky deposits yes
- [with precautions]



Multi stage roots dry pump

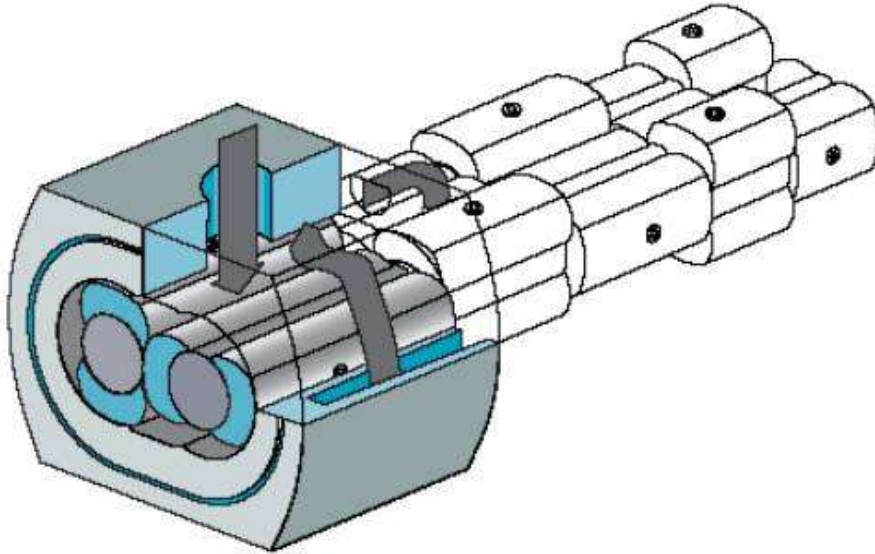

USP: Hydrocarbon free,
Low power consumption.

Cost: Medium

Negative: Low tolerance to dust / deposits

Pumping speed range:
10 m³/hr > 400 m³/hr

End pressure:
10-2 mbar

Applications:

- Air yes
- Inert gases yes
- He / H₂ yes
- Flammable yes
- Pyrophoric yes
- Reactive yes
- Radioactive Yes
- [Special pump only]
- Toxic yes
- Vapours yes
- Hot gases yes
- Dust no
- Sticky deposits no



Diaphragm dry pump

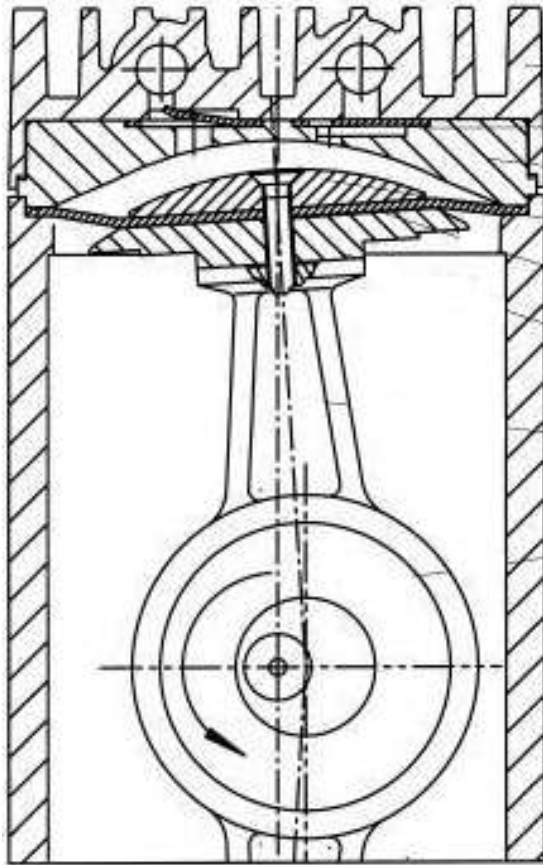

USP: Hydrocarbon free

Cost: Low

Negative: Fatigue of diaphragm

Pumping speed range:
1 m³/hr > 20 m³/hr

End pressure:
10 mbar

Applications:

- | | |
|-----------------------|------|
| - Air | yes |
| - Inert gases | yes |
| - He / H ₂ | poor |
| - Flammable | no |
| - Pyrophoric | no |
| - Reactive | no |
| - Radioactive | no |
| - Toxic | no |

[Special pump only]

- | | |
|-------------------|-----------------|
| - Vapours | no condensables |
| - Hot gases | no |
| - Dust | no |
| - Sticky deposits | no |



Rotary vane wet pump

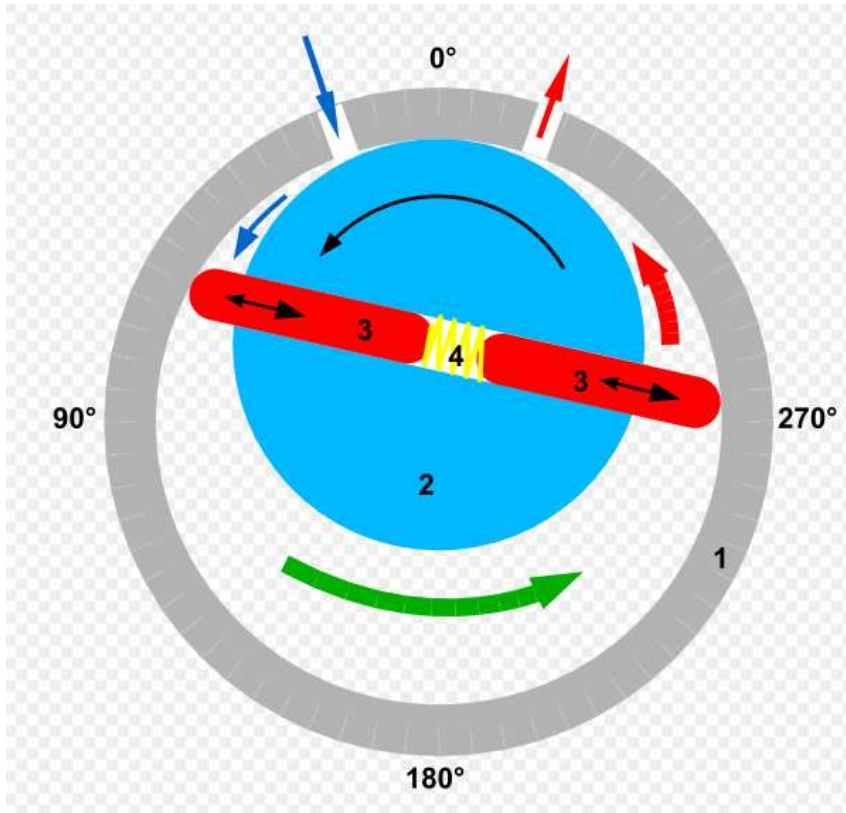

USP: Low cost high compression

Cost: Low

Negative: Oil wetted pumping chamber

Pumping speed range:
1 m³/hr > 1200 m³/hr

End pressure:
10⁻³ mbar



leybold

Applications: [Depending on lubricant]

- Air yes
- Inert gases yes
- He / H₂ yes
- Flammable yes
- Pyrophoric yes
- [Special pump only]
- Reactive yes
- [Special pump only]
- Radioactive no
- Toxic no
- Vapours no condensables
- Hot gases no
- Dust no
- Sticky deposits no

Rotary piston wet pump

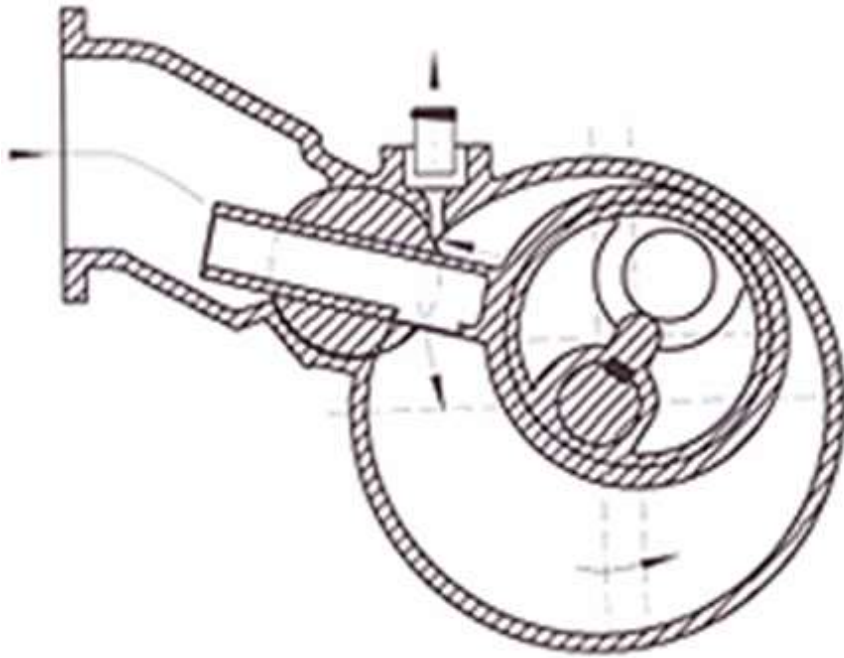

USP: Robust lower cost high compression

Cost: Medium

Negative: Oil wetted pumping chamber, vibration.

Pumping speed range:
100 m³/hr > 1200 m³/hr

End pressure:
10-2 mbar

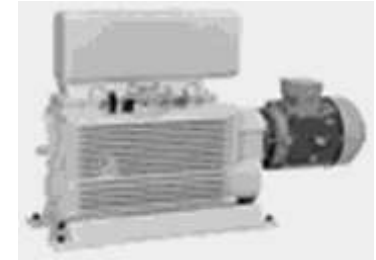

Applications: [Depending on lubricant]

- | | |
|-----------------------|----------------------------|
| - Air | yes |
| - Inert gases | yes |
| - He / H ₂ | yes |
| - Flammable | yes |
| - Pyrophoric | no |
| - Reactive | no |
| - Radioactive | no |
| - Toxic | no |
| - Vapours | avoid condensation |
| - Hot gases | no |
| - Dust | yes |
| | [with regular oil changes] |
| - Sticky deposits | yes |
| | [with regular oil changes] |

- 1 Vacuum family tree
- 2 Fore vacuum mechanisms – pressure & speed range
- 3 High vacuum mechanisms – pressure & speed range
- 4 Fore vacuum pump applications
- 5 High vacuum pump applications**
- 6 Future developments

Applications – process gases

Fore Vacuum

- Air
- Inert gas
- Helium / Hydrogen
- Flammables
- Pyrophoric
- Corrosive
- Radioactive
- Toxic
- Vapours
- Hot gases
- Dusts
- Sticky deposits

High Vacuum

- Air
- Inert gas
- Helium / Hydrogen
- Flammables
- Corrosives
- Toxic
- Vapours

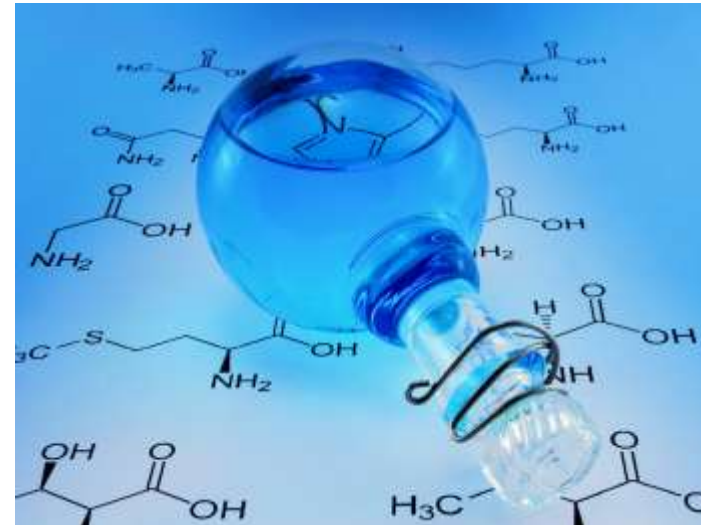

Turbo molecular pump

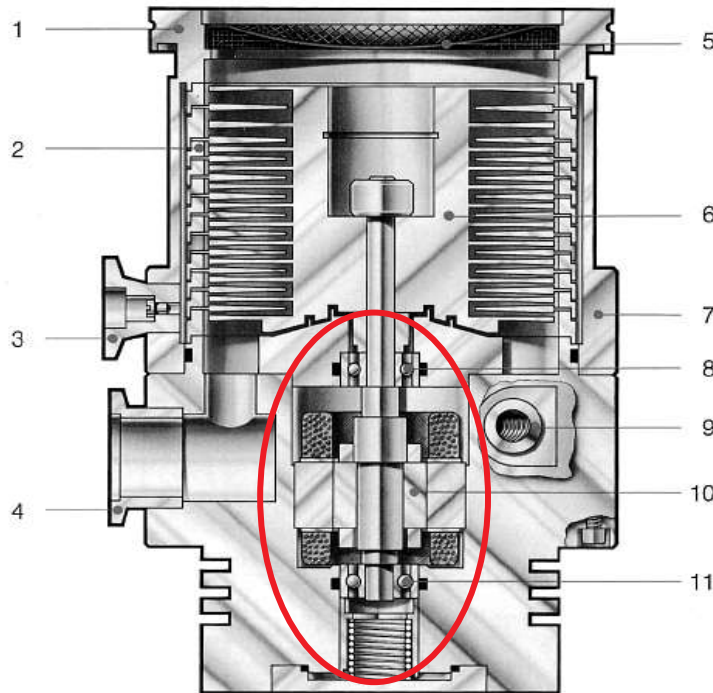

- | | | |
|------------------------------|-------------------|-----------------------|
| 1 Hochvakuumanschlußflansch; | 5 Splitterschutz; | 9 Kühlwasseranschluß; |
| 2 Stator-Paket; | 6 Rotor; | 10 3-Phasen-Motor; |
| 3 Belüftungsanschlußflansch; | 7 Pumpengehäuse; | 11 Kugellager |
| 4 Vorvakuumanschlußflansch; | 8 Kugellager; | |

USP: Hydrocarbon free, low vibration.
Direct tool mounting.

Cost: Medium to High

Negative: Not tolerant of particles

Pumping speed range:
50 l/s > 5000 l/s

End pressure:
10-10 mbar

Applications:

- | | |
|-----------------------|---------------------------------|
| - Air | yes |
| - Inert gases | yes |
| - He / H ₂ | yes |
| | [below 10-2 mbar] |
| - Flammable | no |
| - Pyrophoric | no |
| - Reactive | no |
| - Radioactive | no |
| | [Yes if no electronics in pump] |
| - Toxic | no |
| - Vapours | yes |
| | [Heated versions] |
| - Hot gases | yes |
| | [Below 10-2 mbar] |
| - Dust | no |
| - Sticky deposits | yes |
| | [Heated versions] |



Diffusion pump

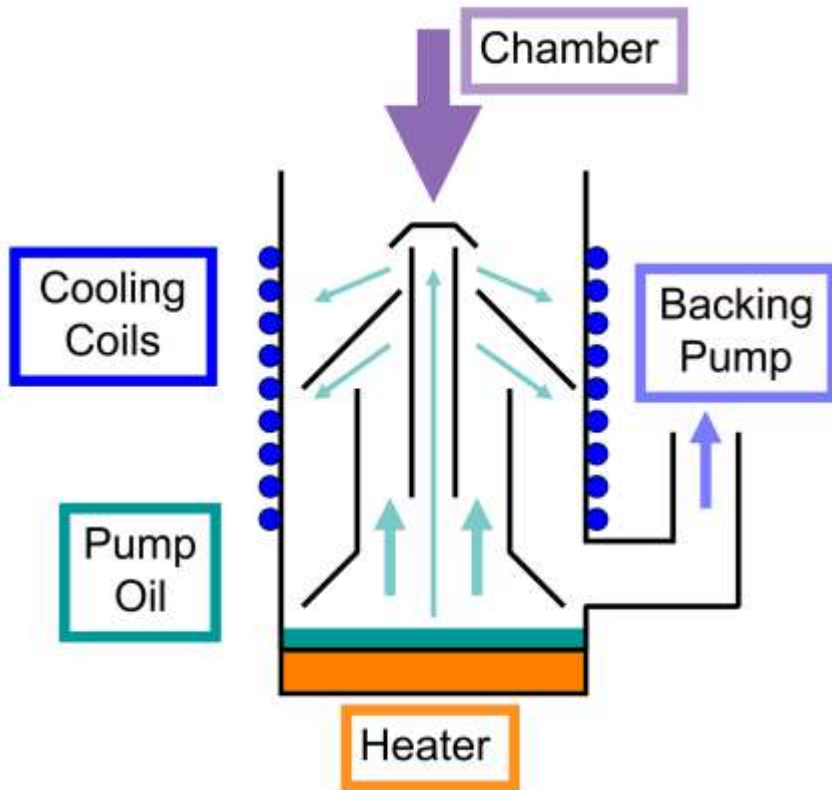

USP: Good light gas compression,
Tolerant of industrial applications,
including particles.

Cost: Low

Negative: Possibility of oil transfer

Pumping speed range:
50 l/s > 50000 l/s

End pressure:
10⁻⁸ mbar

Applications:

- | | |
|-----------------------|-----------------|
| - Air | yes |
| - Inert gases | yes |
| - He / H ₂ | yes |
| - Flammable | no |
| - Pyrophoric | no |
| - Reactive | no |
| - Radioactive | no |
| - Toxic | yes |
| - Vapours | no condensables |
| - Hot gases | no |
| - Dust | no |
| - Sticky deposits | no |



Cryo pump

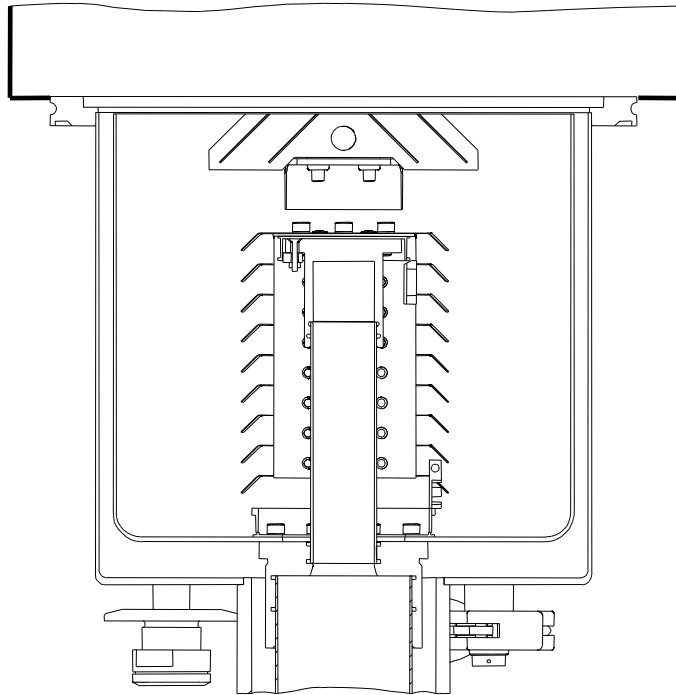

USP: hydro carbon free vacuum; high pumping speed

Cost: high

Negative: regeneration needed from time to time

Pumping speed range:
800 l/s > 60000 l/s

End pressure:
10-10 mbar

Applications:

- | | |
|-----------------------|-----------------|
| - Air | yes |
| - Inert gases | yes |
| - He / H ₂ | yes |
| - Flammable | no |
| - Pyrophoric | no |
| - Reactive | no |
| - Radioactive | no |
| - Toxic | yes |
| - Vapours | no condensables |
| - Hot gases | no |
| - Dust | no |
| - Sticky deposits | no |



- 1 Vacuum family tree
- 2 Fore vacuum mechanisms – pressure & speed range
- 3 High vacuum mechanisms – pressure & speed range
- 4 Fore vacuum pump applications
- 5 High vacuum pump applications
- 6 Future developments**

Where next - applications?

Segmentation:

- Specific applications demand more specialised vacuum pumps.
- E.g.
 - Multi inlet turbo
 - ATEX pumps
 - Hydrogen pumps
 - High compression turbo
 - High throughput turbo



Where next - applications?

Special solution

We provide clean processes ...

In many coating processes deposits may form on the housing surfaces and the rotors of the DRYVAC screw pumps. These process deposits can be dissolved with an automated and integrative cleaning process.



Our solution:

DRYVAC 5000RS-i with integrated cleaning system



Features

Vacuum pump system consisting of:

- DRYVAC 5000RS-i
- Touchscreen control
- Special seal design allows DRYVAC pump to be filled with cleaning solution
- Recirculation of cleaning solution increases effectiveness
- Extends overhaul intervals
- Cleaning can be done in-situ

- Cleaning solution can be customized for each application
- Cleaning process with automatic operation of all valves, pressure and speed control
- Intuitive operation
- Remote control via 24V digital I/O
- Pump tolerant of aggressive cleaning solutions

Technical performance data

DRYVAC 5000RS-i with integrated cleaning system	
High vacuum range	DN 250 ISO-K
Pumping speed [m ³ /h]	3600

Application expertise:

- Specific applications demand more specialised accessories.
 - Cleaning techniques
 - Hot traps
 - Dust traps
 -
- Specific application recommendations
 - Pump operating temperatures
 - Purge flows
 - Oils
 - Operating cleaning procedures

Where next - products?



Pushing the limits:

- Lower price.
- Increase reliability
- Lower cost of ownership
 - Reduced maintenance
 - Reduced power consumption
 - Reduced gas consumption
- Better communications

Benefits of DRYVAC dry pumps

- Maintenance free operation in most applications
- Robust against particles and deposits
- Less sensitivity against shock venting
- Flexibility
- Self protection in case of exceeding the operation limits or mal operation
- Lower power

Where next - products?

Pushing the limits:

- Lower price.
- Increase reliability
- Lower cost of ownership
 - Reduced maintenance
 - Reduced power consumption
 - Reduced gas consumption
- Better communications

Benefits of TURBOVAC MAGiNTEGRA

- Maintenance free operation in most applications
- Robust against particles and deposits
- Less sensitivity against shock venting
- Monitoring of operation limits
- Self protection in case of exceeding the operation limits or mal operation



Thank you.

