

Dry Pump Technology

R Gordon Livesey

Dry Pumping

- No oil backstreaming into process chamber
- No contamination of process stream
- Effluent/waste disposal costs reduced or eliminated
- Lower maintenance costs
- Tolerant to heat load
- Lower utility costs
- Solvent recovery
 - Flavours, perfumes, fuel vapours
- Deodorization
- Evaporation/distillation
- Drying
 - Brake fluid, oils
- Desorption
- Seawater deaeration
- Steel degassing
- Semicon processes
- UHV

Dry Pump Technologies

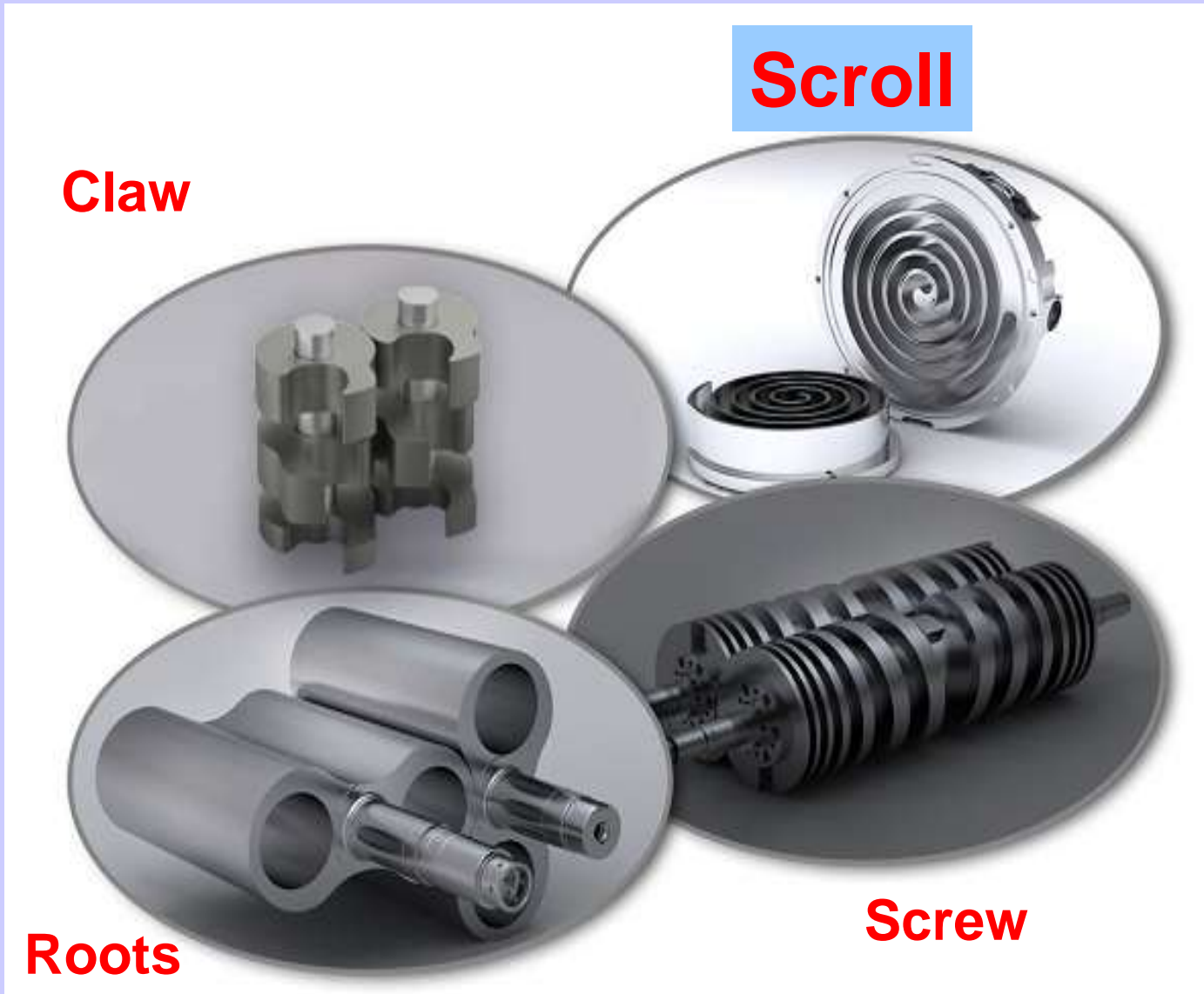

Scroll Pumps

- Comprises two opposing scrolls
- One scroll is fixed and the other orbits
- Each has a seal in the scroll end



Scroll Mechanism

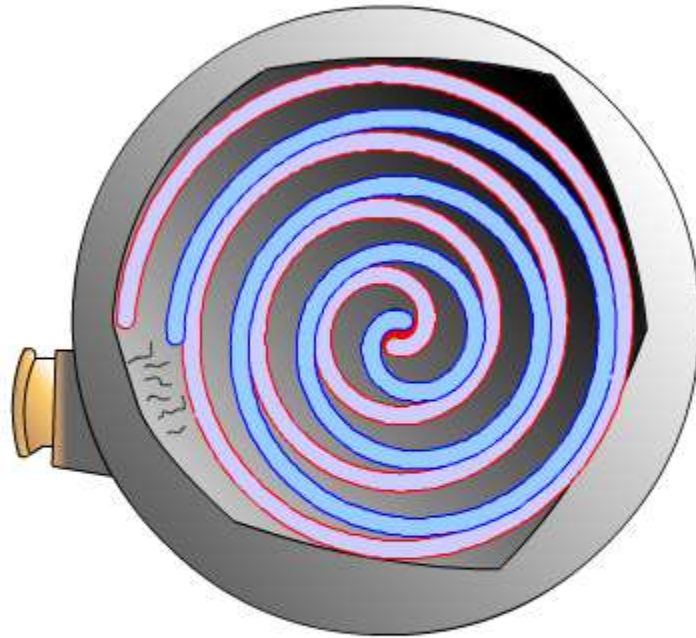



Scroll Pump

- Small exhaust stage
 - Low power at ultimate
- Progressive compression
 - No sudden opening and closing of trapped volumes until final exhaust port
- Concentric arrangement of “stages”
 - Compact mechanism
- Few & simple external seals
- Can be made completely dry with no dynamic seals between lubricant and pump volume
- Reasonable light gas pumping
 - He speed ~ 50% to 70% air speed
 - H₂ , mixed with N₂ for safety reasons



Scroll Pump

- Difficult to extract heat from the exhaust stages
 - Small size, located on axis
- Seal wear generates dust
 - Mainly in first 100 hours, not a major problem if no suckback
 - Successfully used in electron microscopes which are very sensitive to dust
- Seals require frequent maintenance
- Highly vulnerable to solid material ingestion
- Clearances controlled at “whole pump level”
 - Less easy to control critical exhaust clearances
- Only small capacity pumps available – difficult to scale to large sizes

Dry Pump Technologies

Claw



Scroll



Roots



Screw



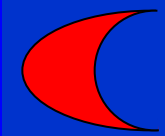

Claw Pumps

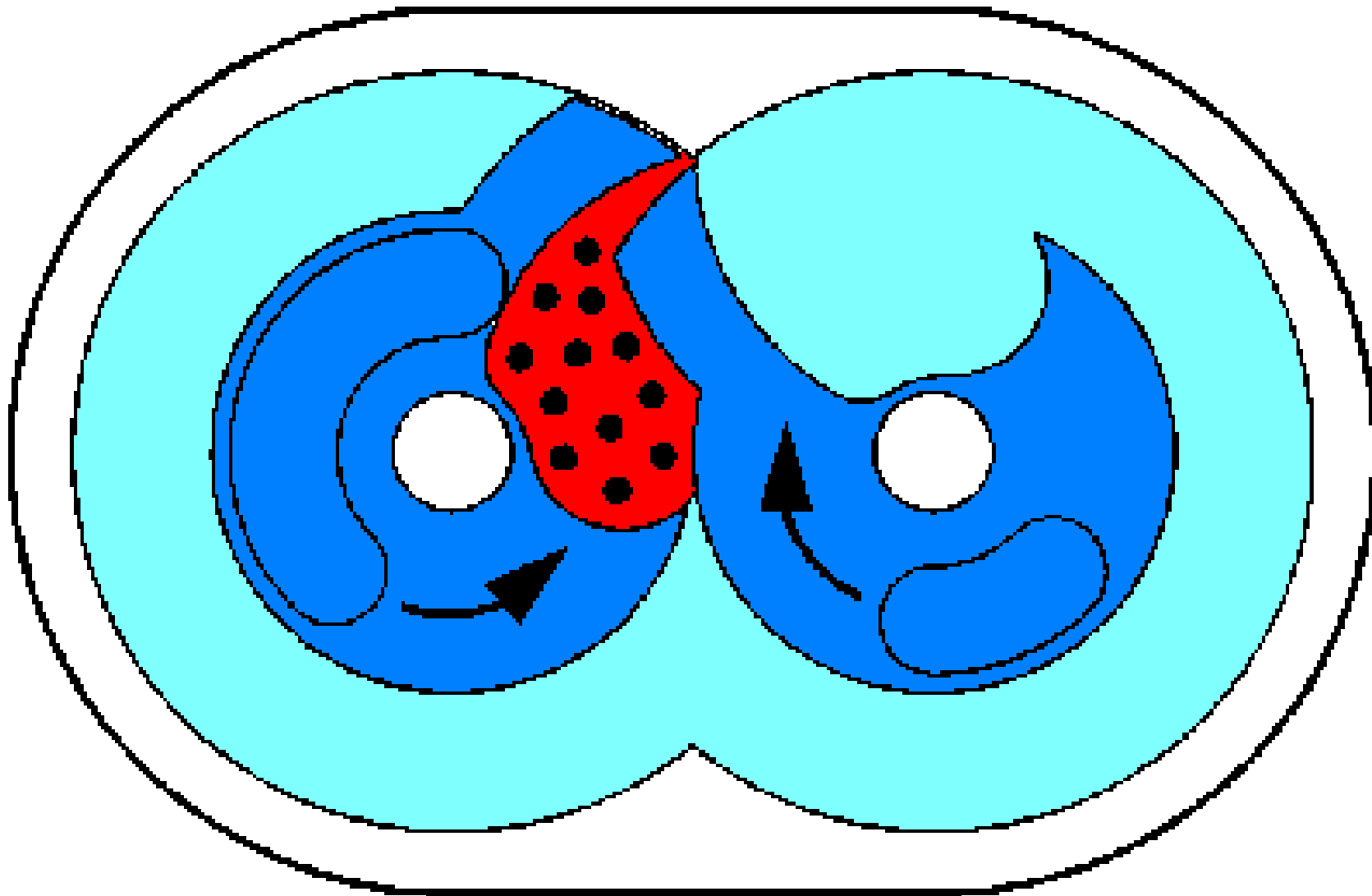

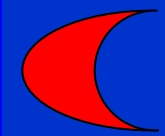

Claw Pumps

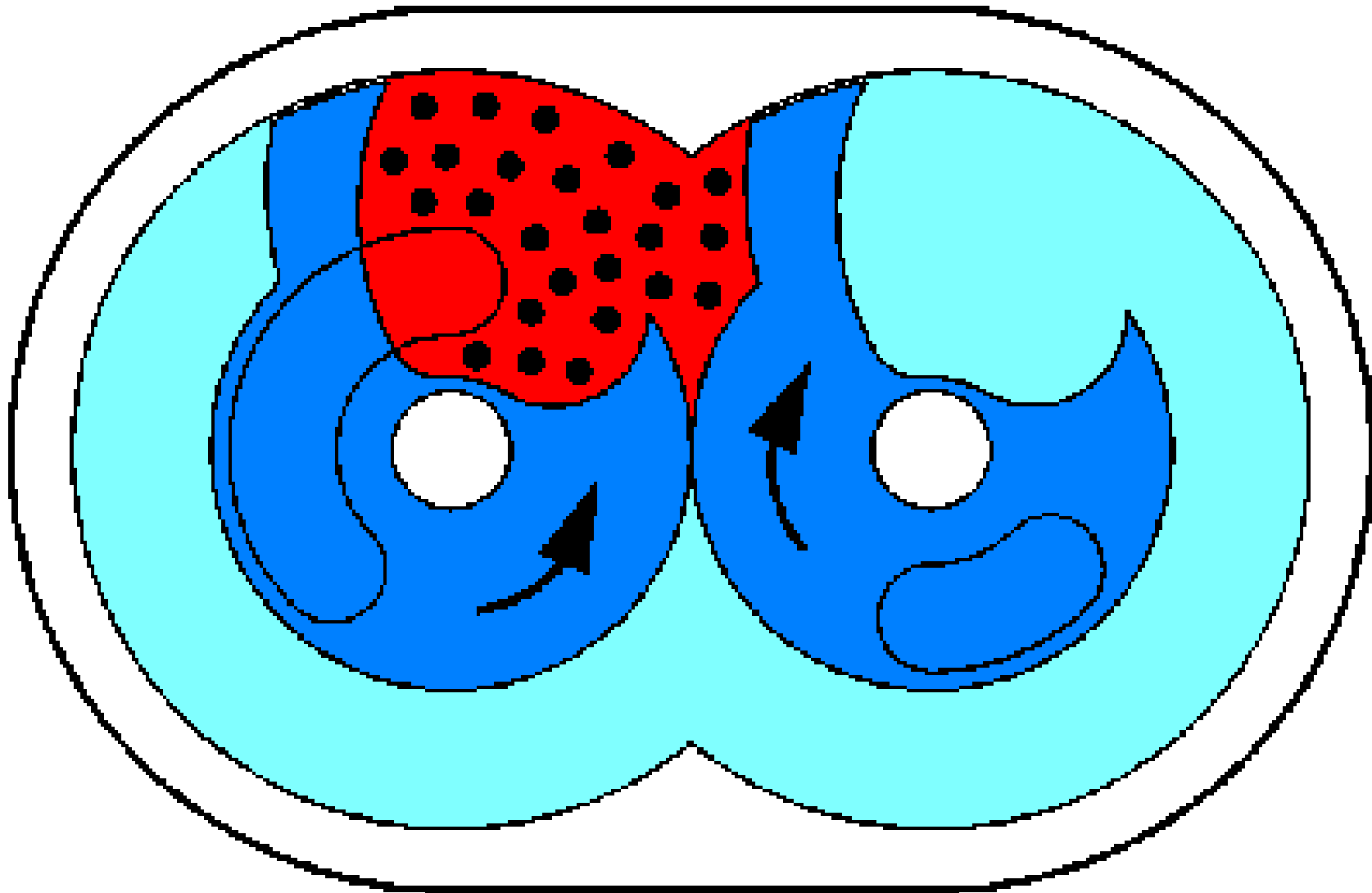

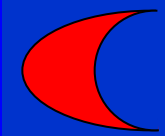

Claw Pumps

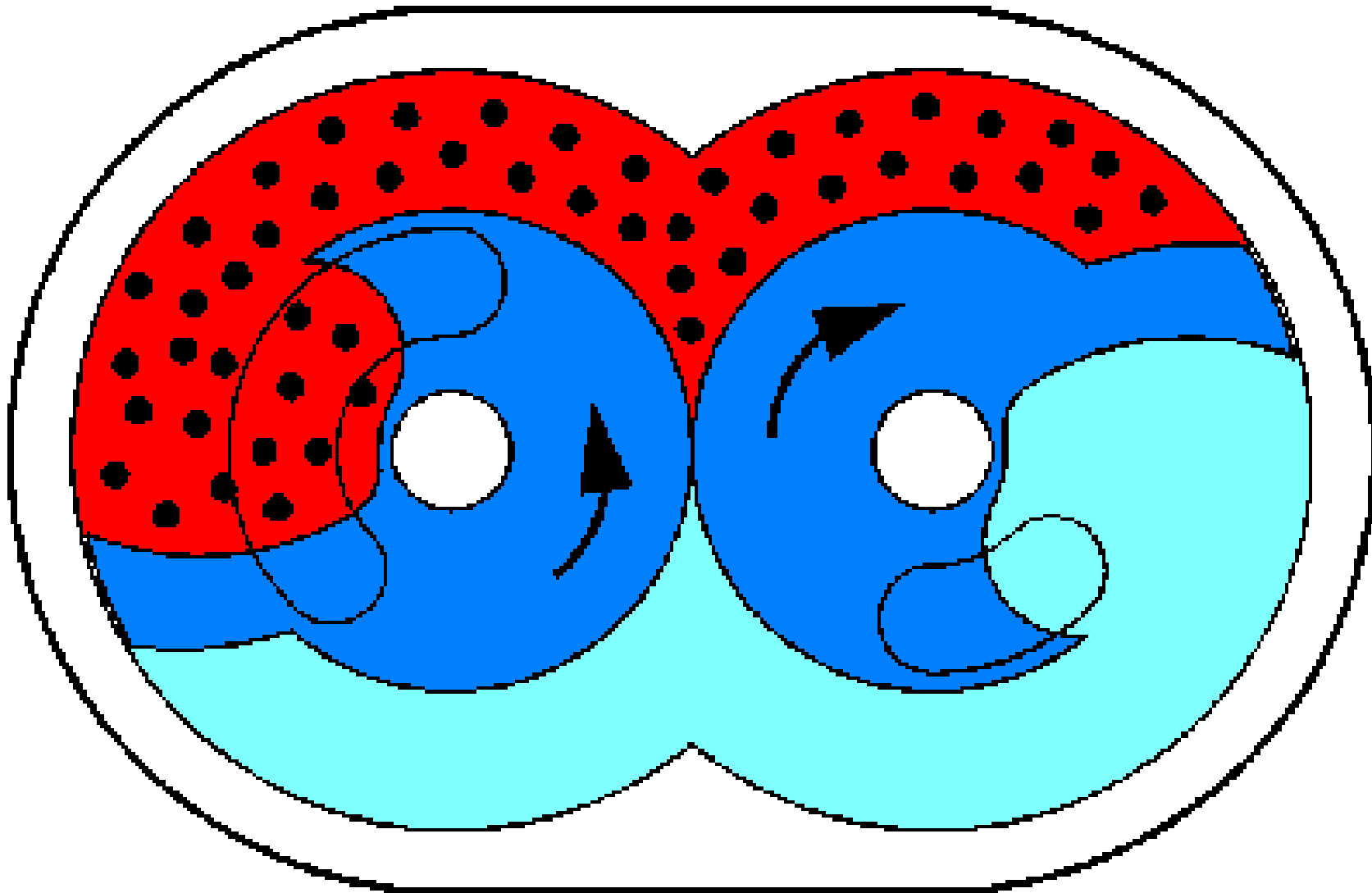

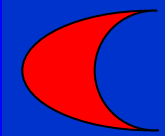

Claw Pumps

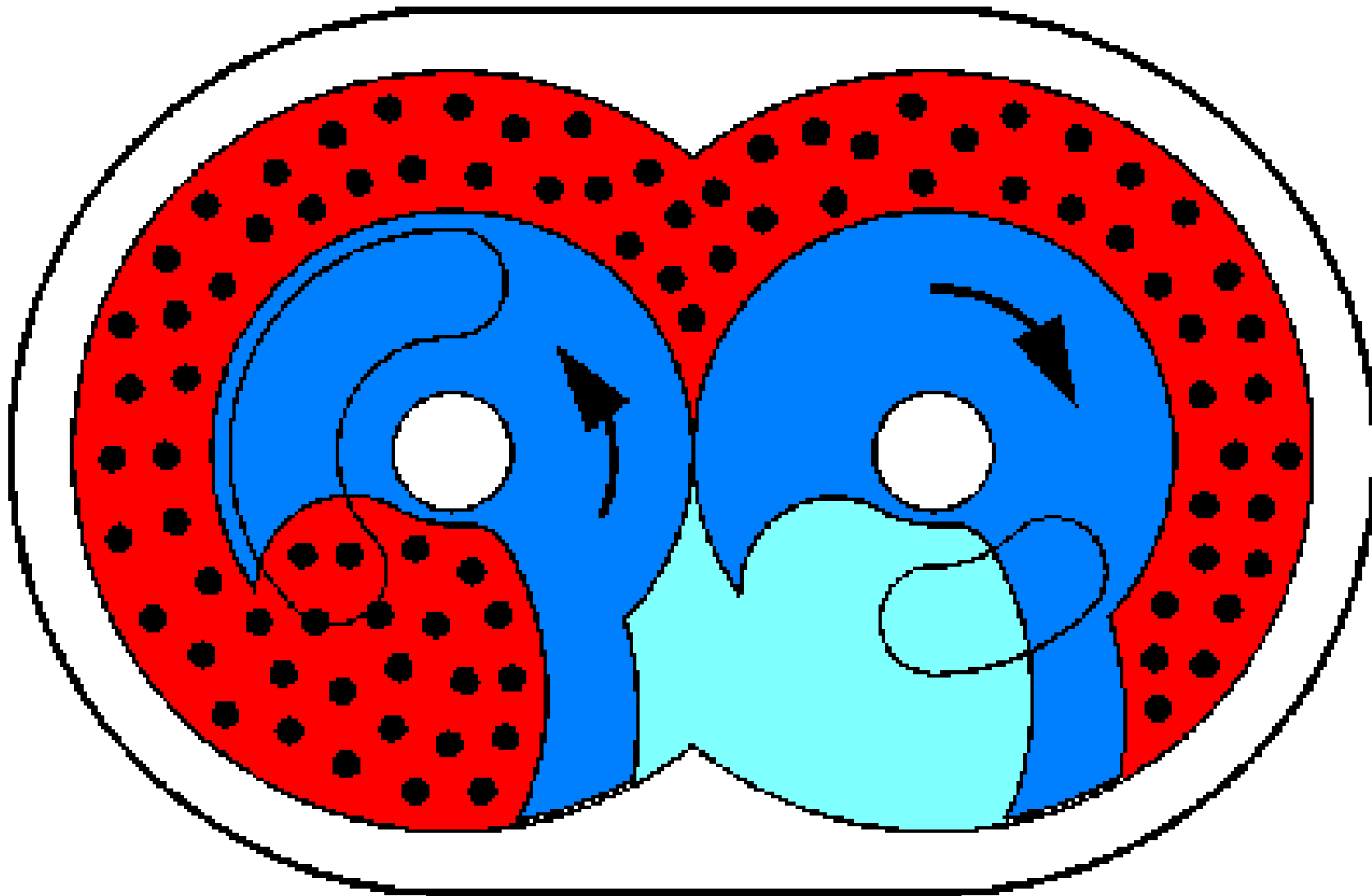

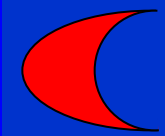

Claw Pumps

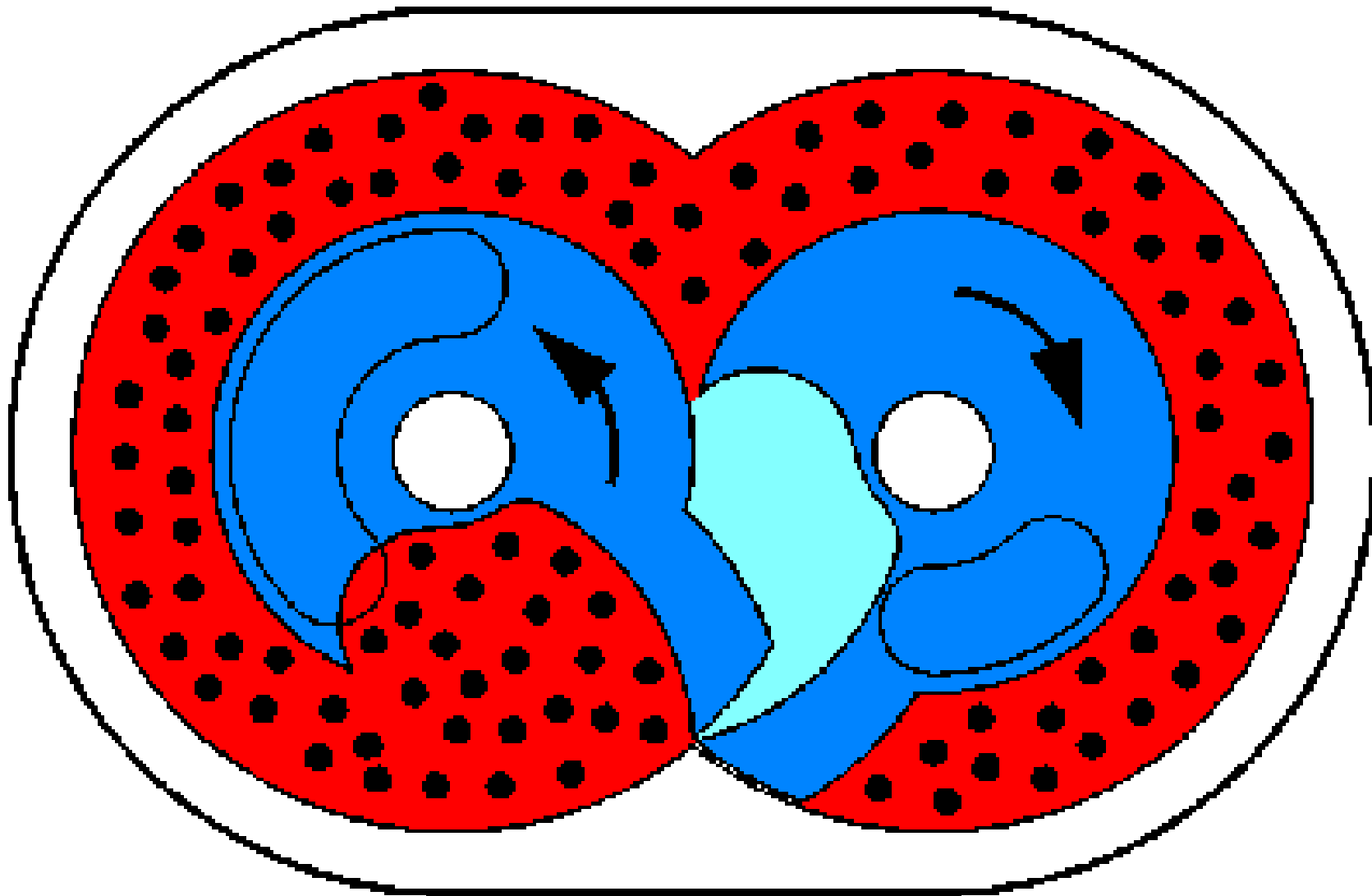

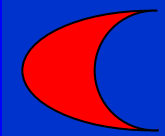

Claw Pumps

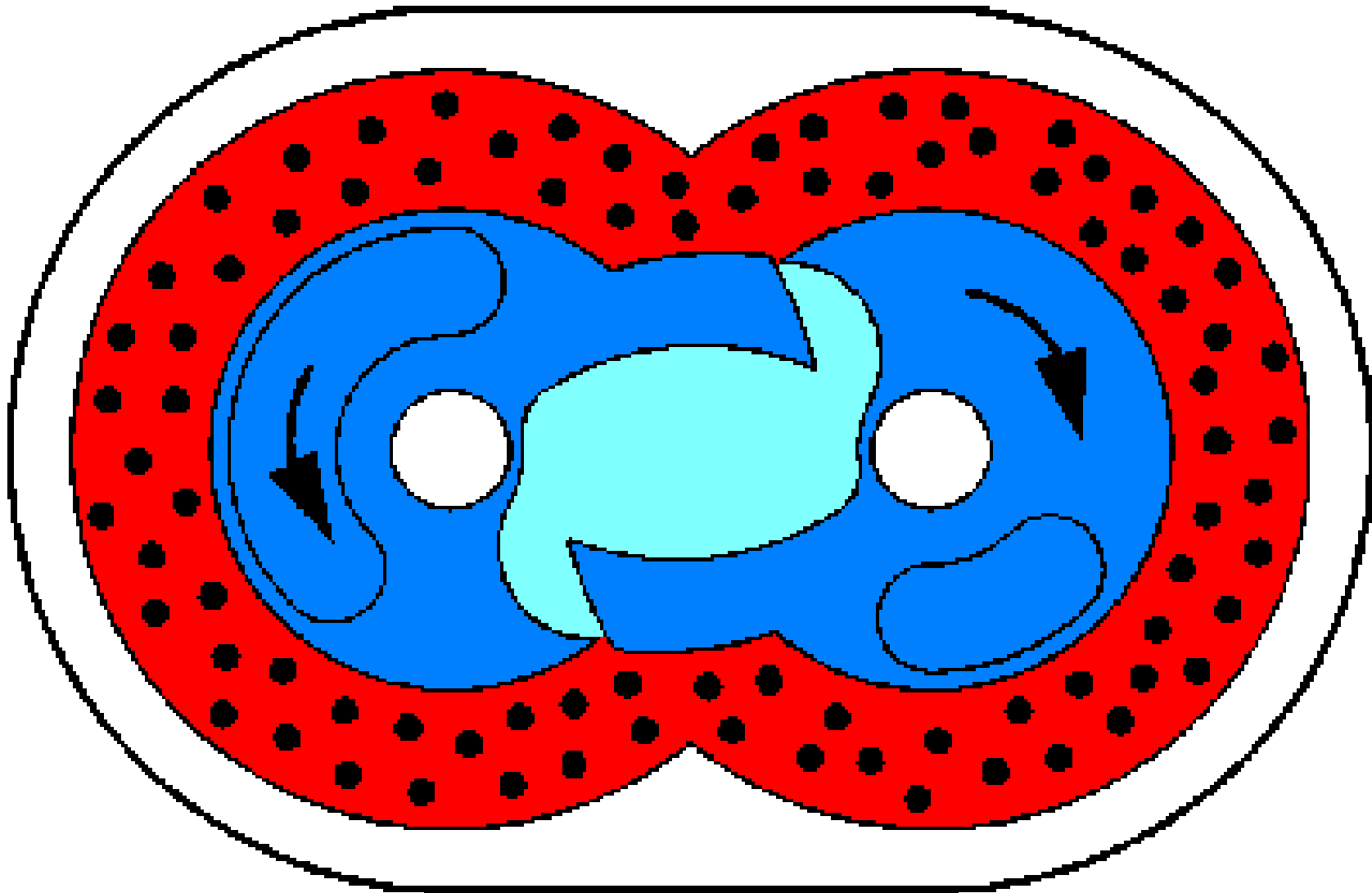

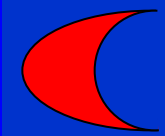

Claw Pumps

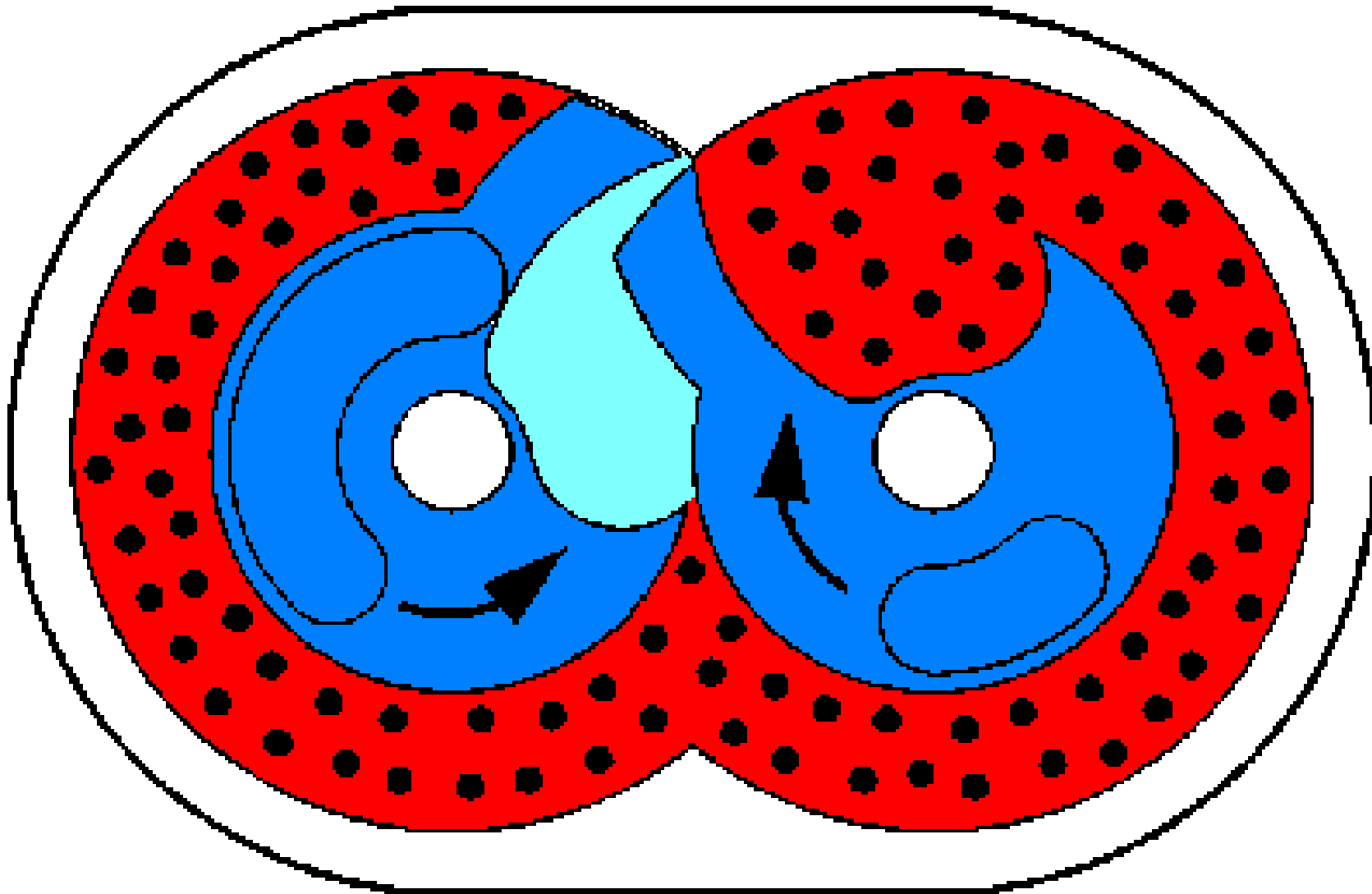

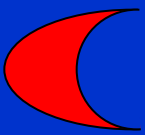

Claw Pumps

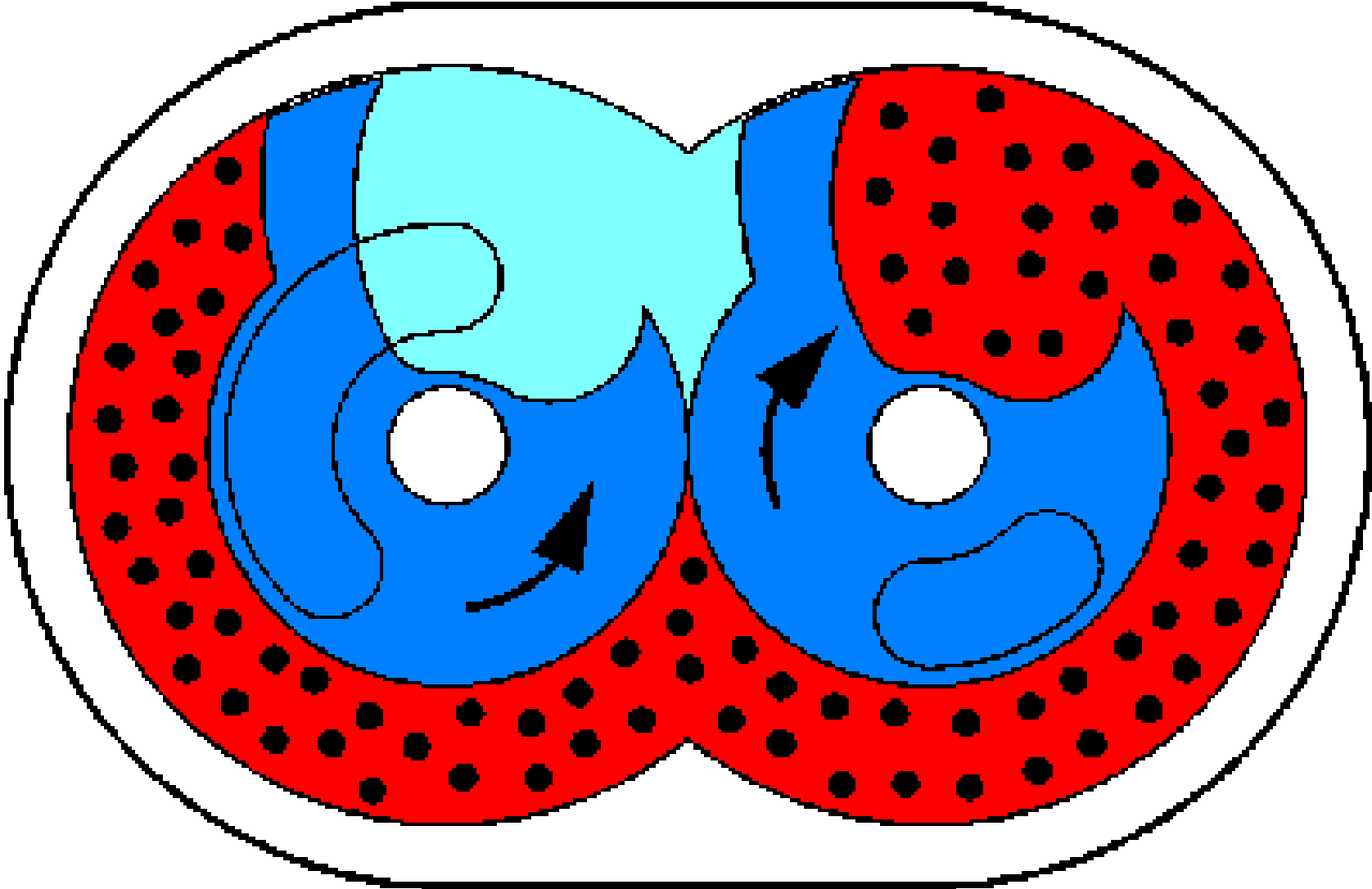

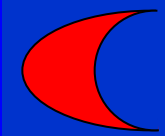

Claw Pumps

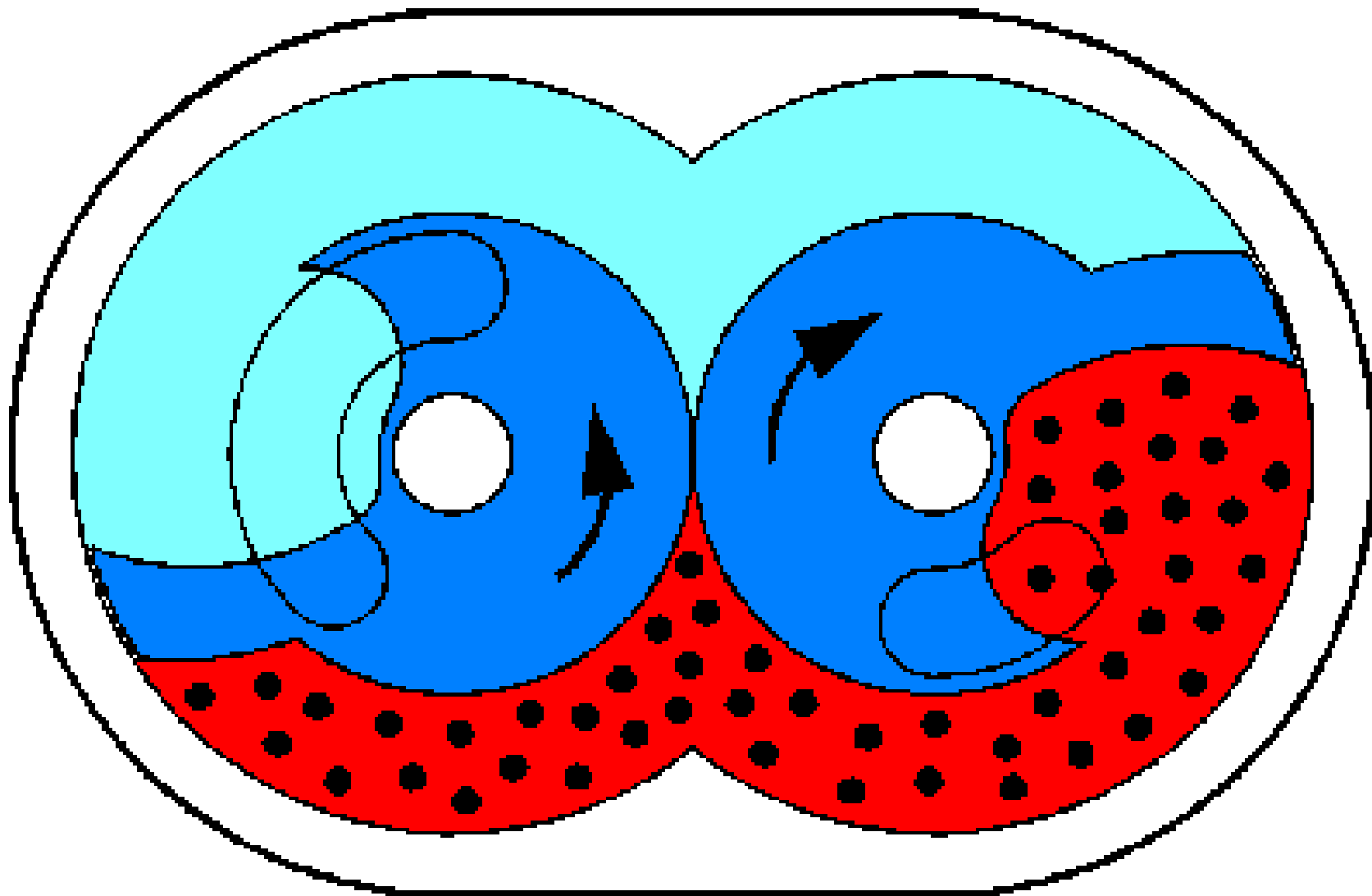

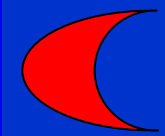

Claw Pumps

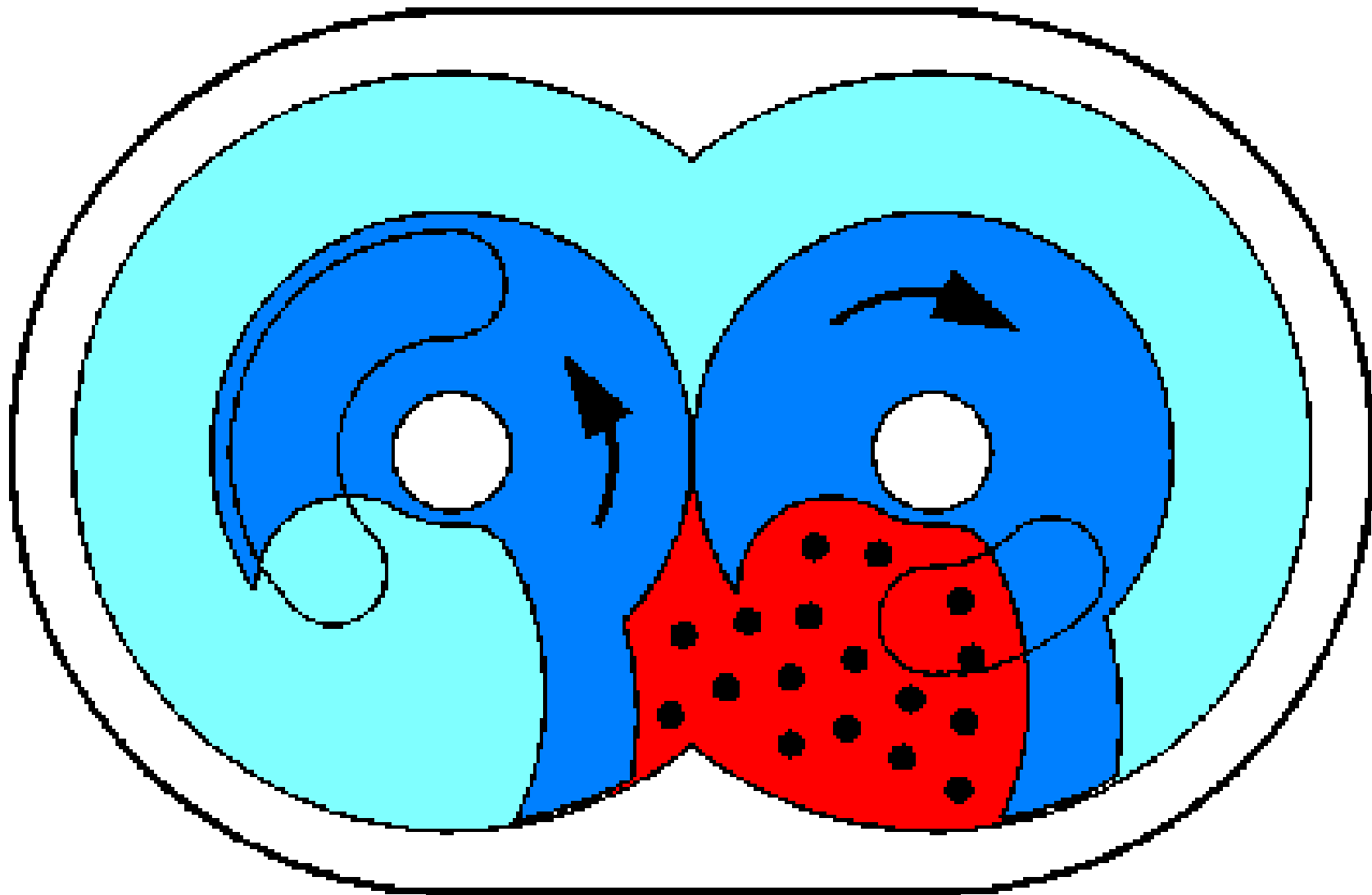

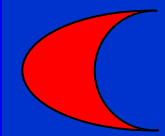

Claw Pumps

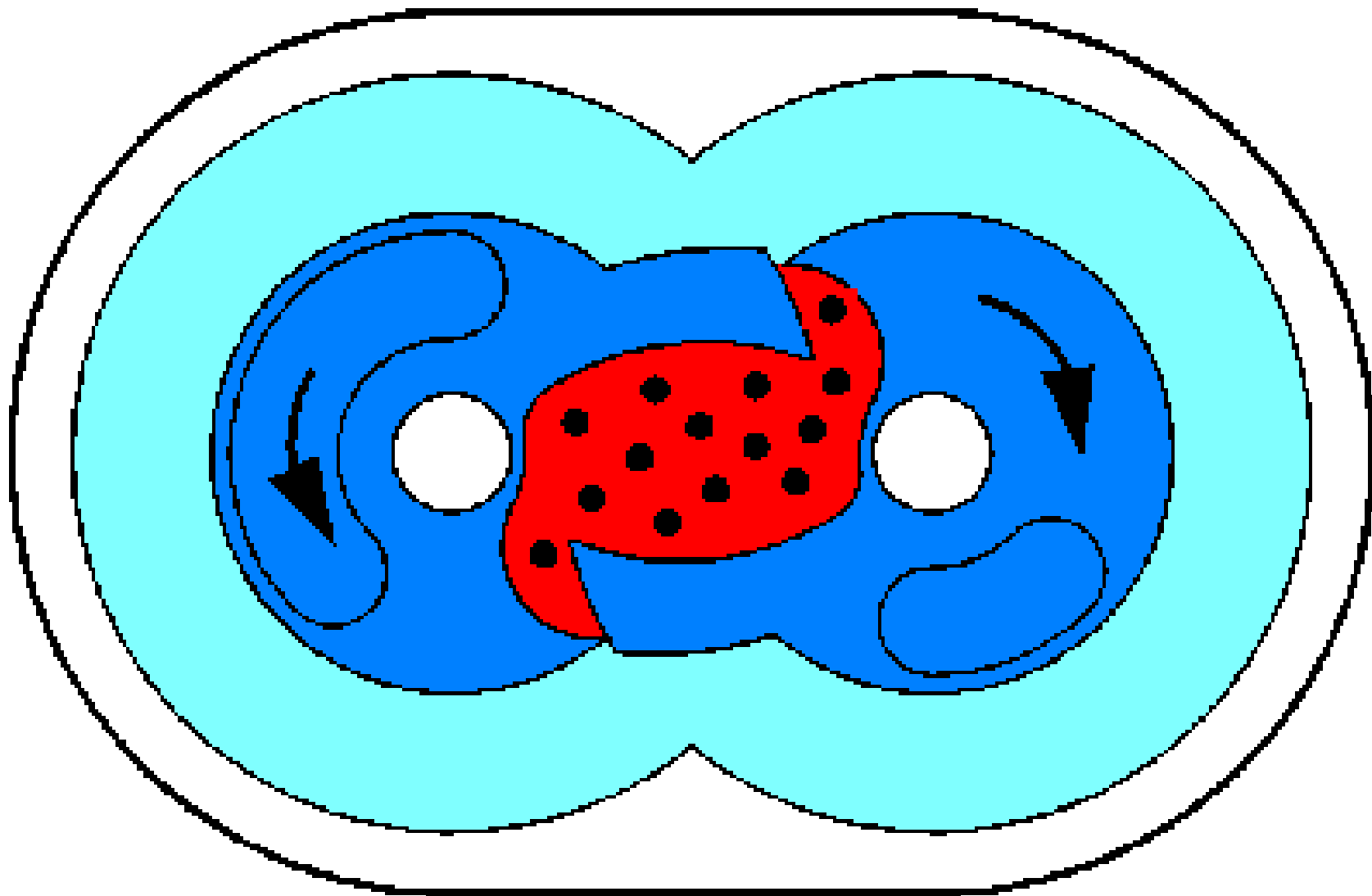

Ideal Compression Ratio

- If V = swept volume and v = dead volume
- It might be thought that the ideal compression ratio $CR = V/v$
- However, the dead volume re-expands into the pump volume and $CR \sim (V/v)^2$

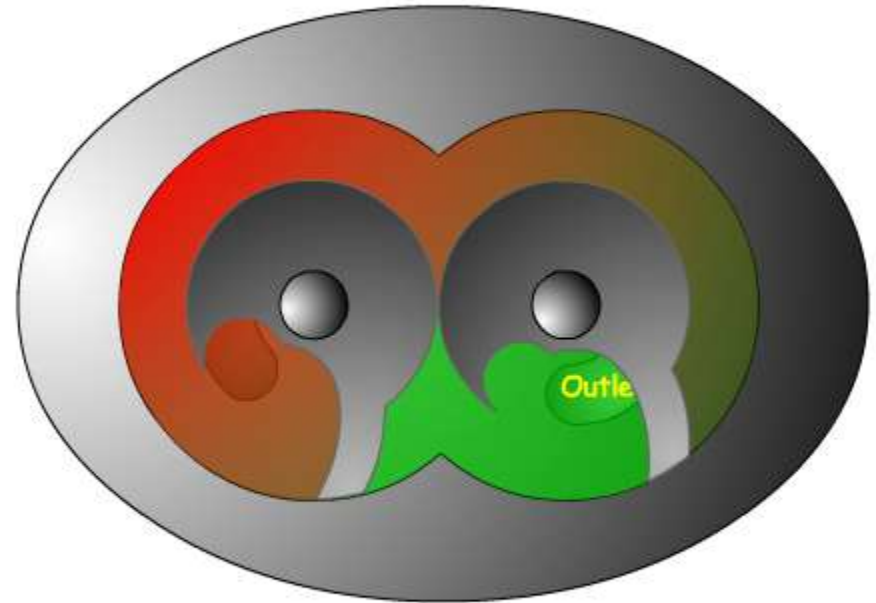

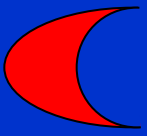

Claw Pumps

- Good compression
- Compression through pump can be controlled by sizing stages
 - Relatively easy to produce small capacity / low power outlet stages
- Reversed claws allow straight path – good dust handling
- Can handle liquid ingestion
- Can be scaled up to moderately large capacities
- Self valving – can exhaust to high pressure

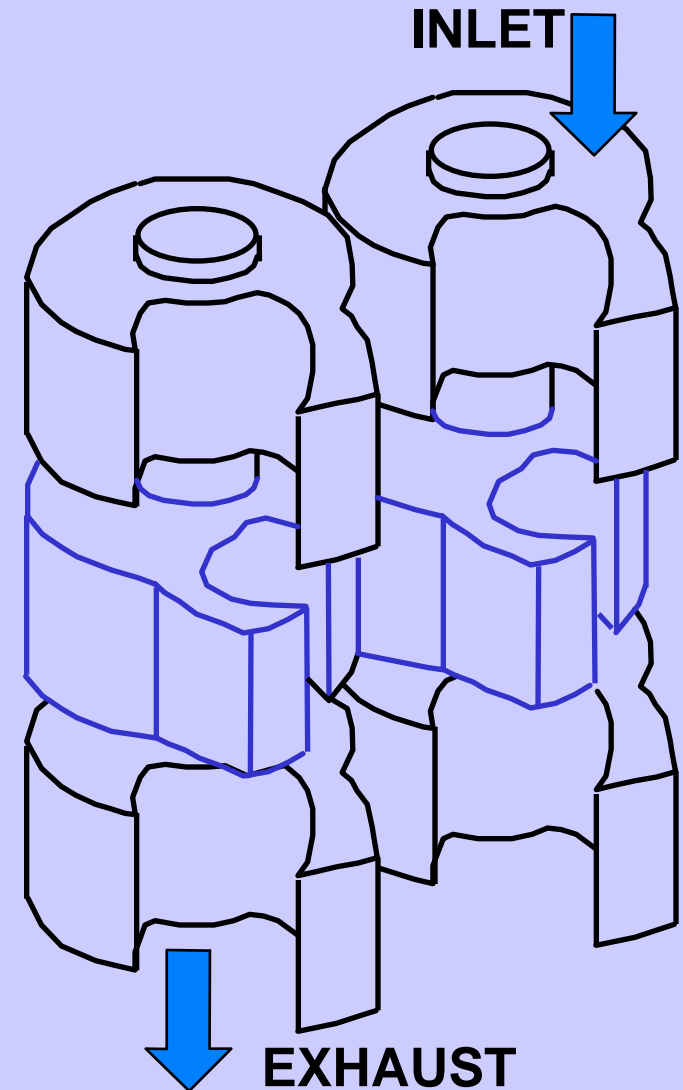



Claw Pumps

- Abrupt compression
 - Exhaust gas re-expands into mechanism at each stage
- Tolerance build up across stages increases clearance at one end of pump (usually inlet)
- Single pulse per rotation at discharge of claw stage
 - High noise when used as an exhaust stage
- Valves and ports can increase power / reduce flow at high pressure
- Lower capacity than same centres Roots
- Relatively poor light gas performance

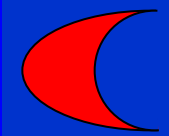

Roots/Claw combination

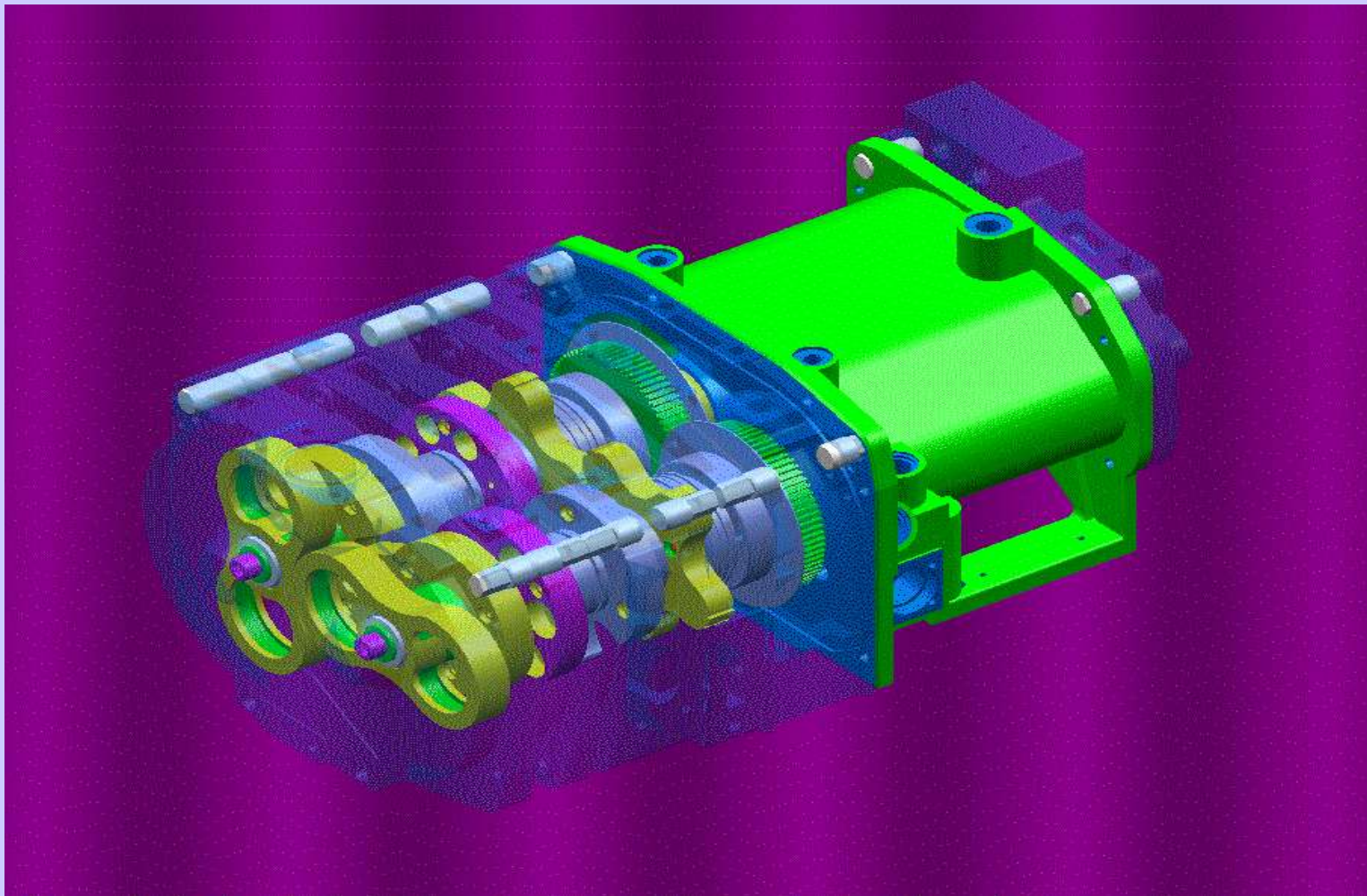

Dry Pump Technologies

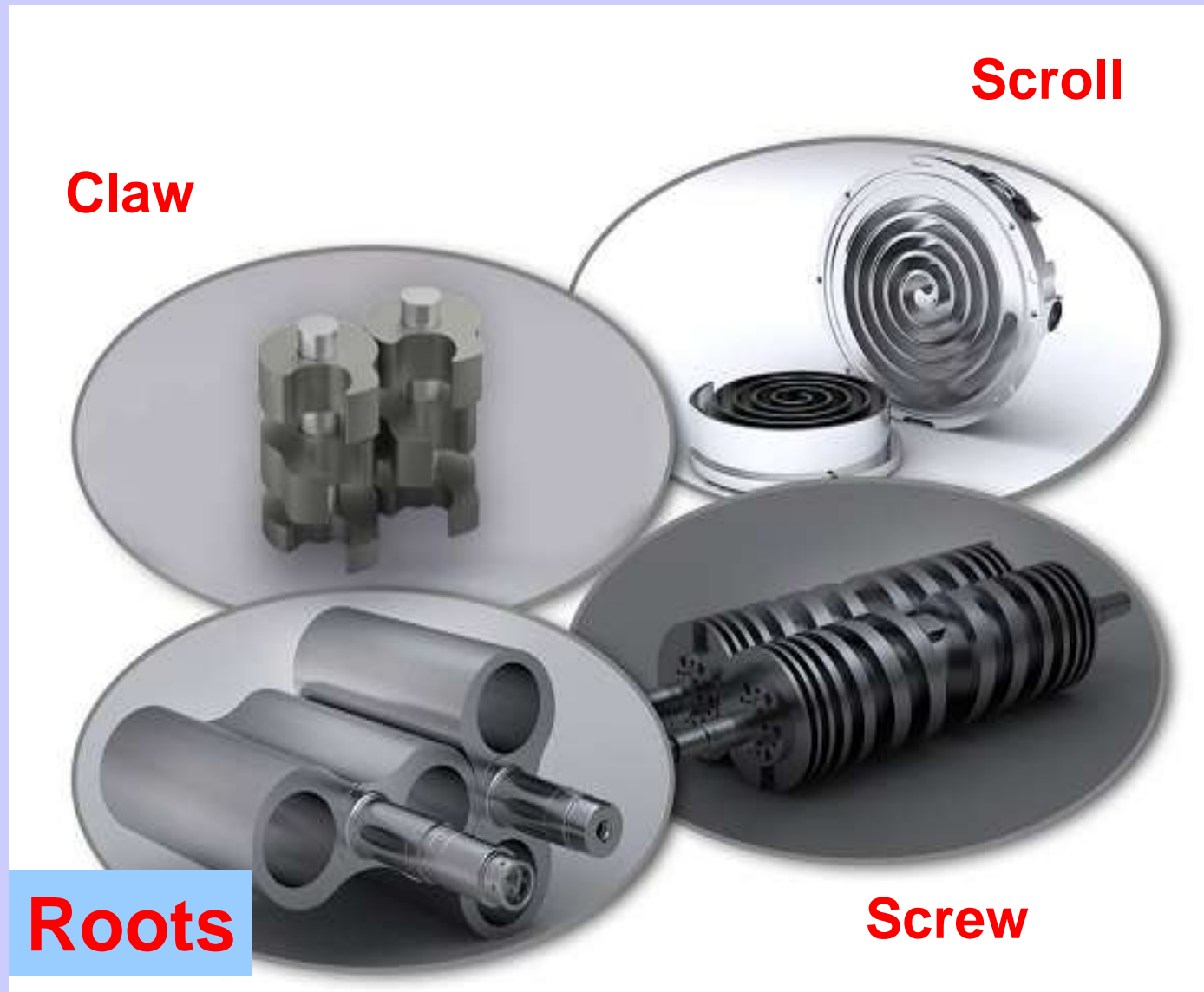

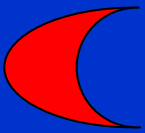

Roots Pumping Cycle

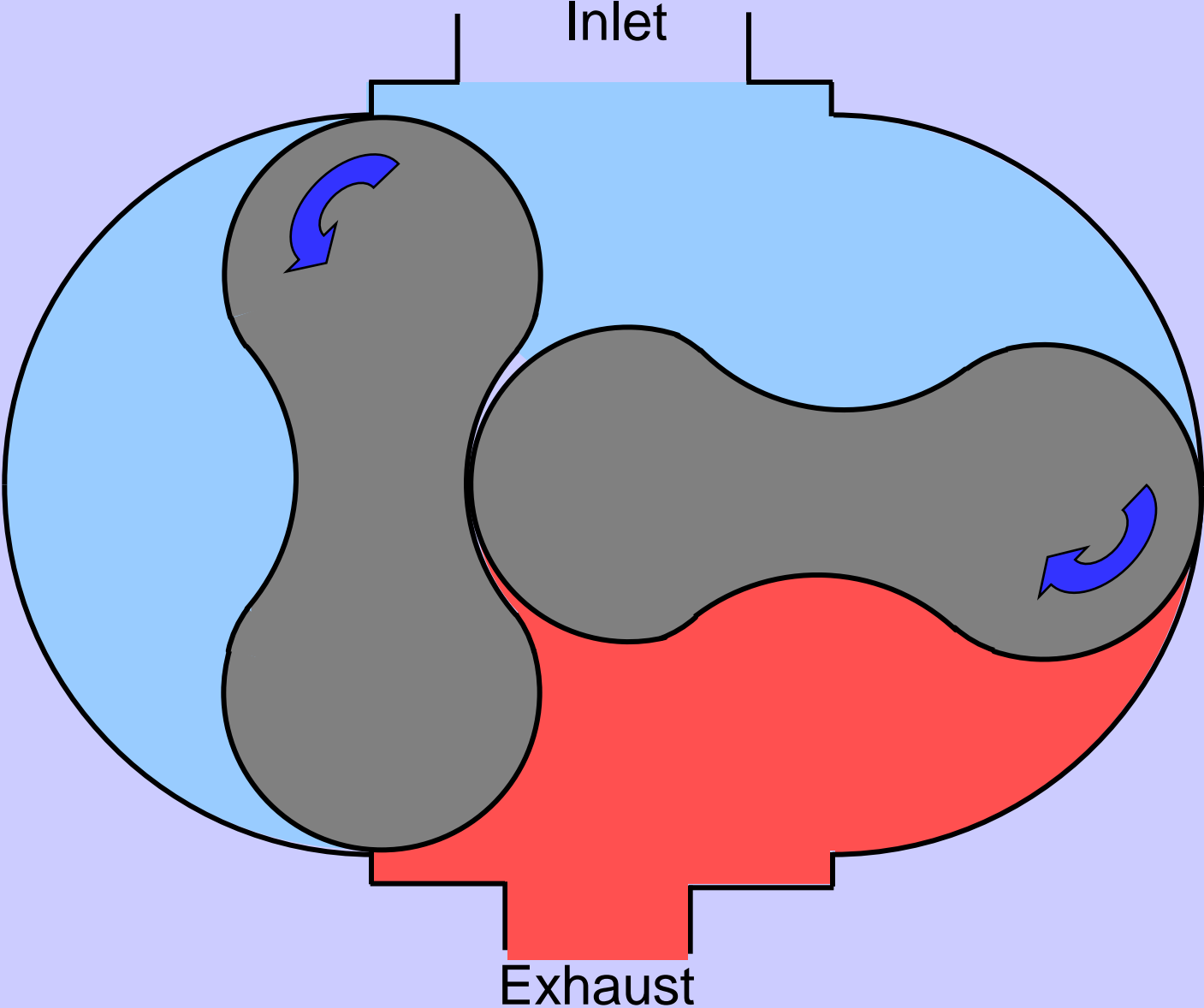

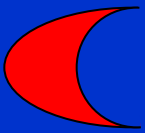

Roots Pumping Cycle

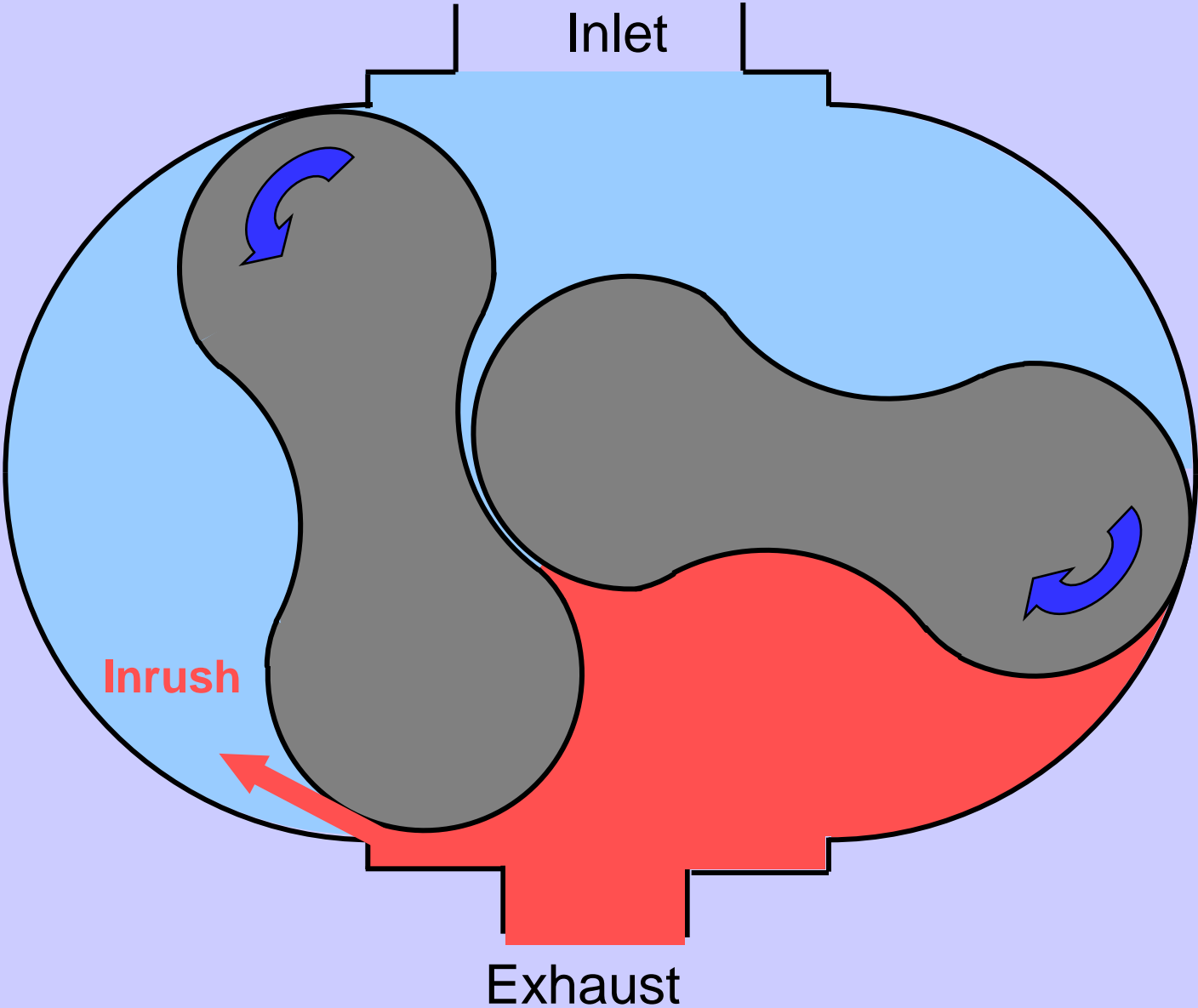

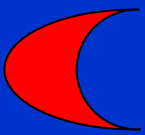

Roots Pumping Cycle

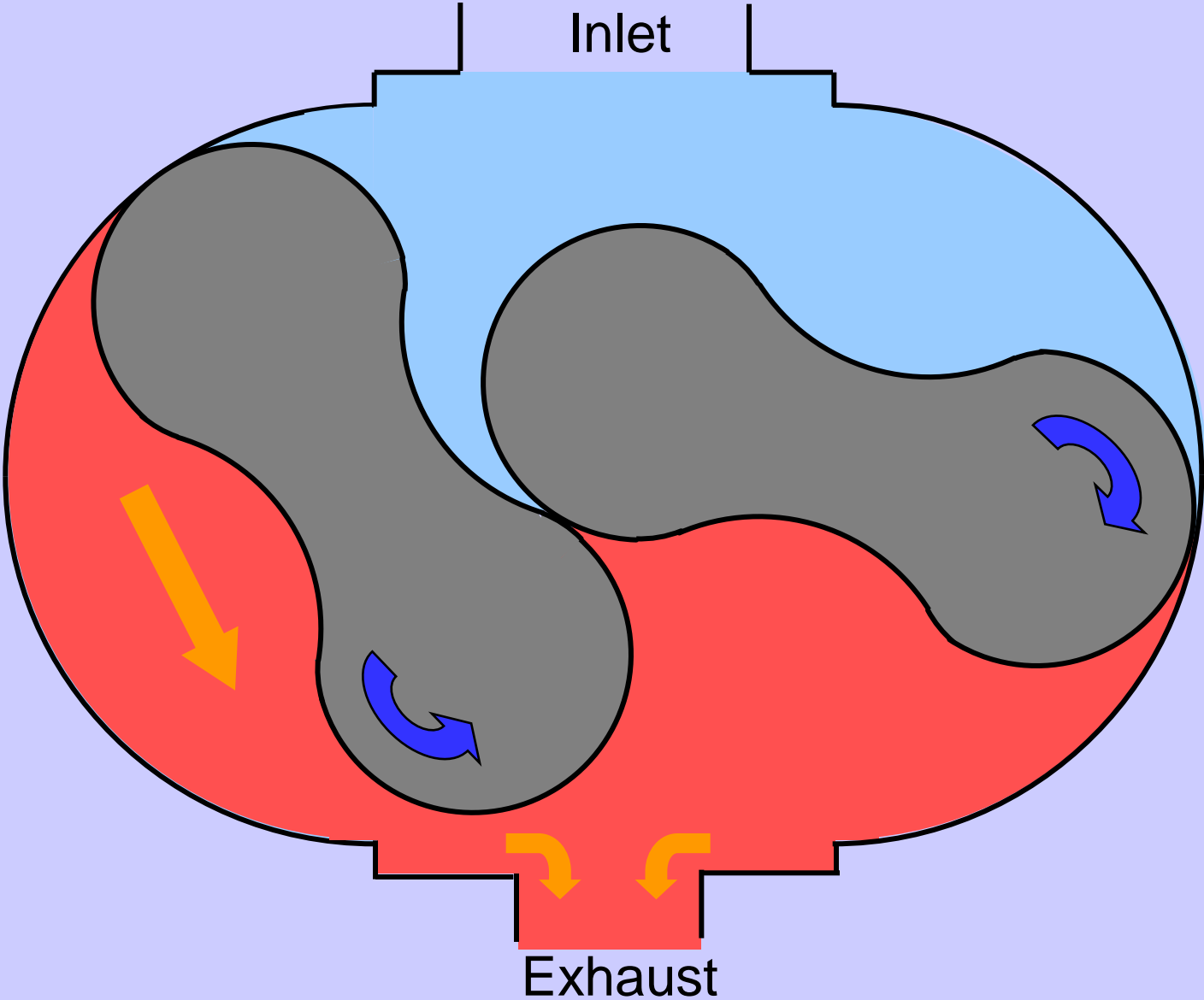

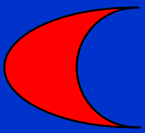

Roots Pumping Cycle

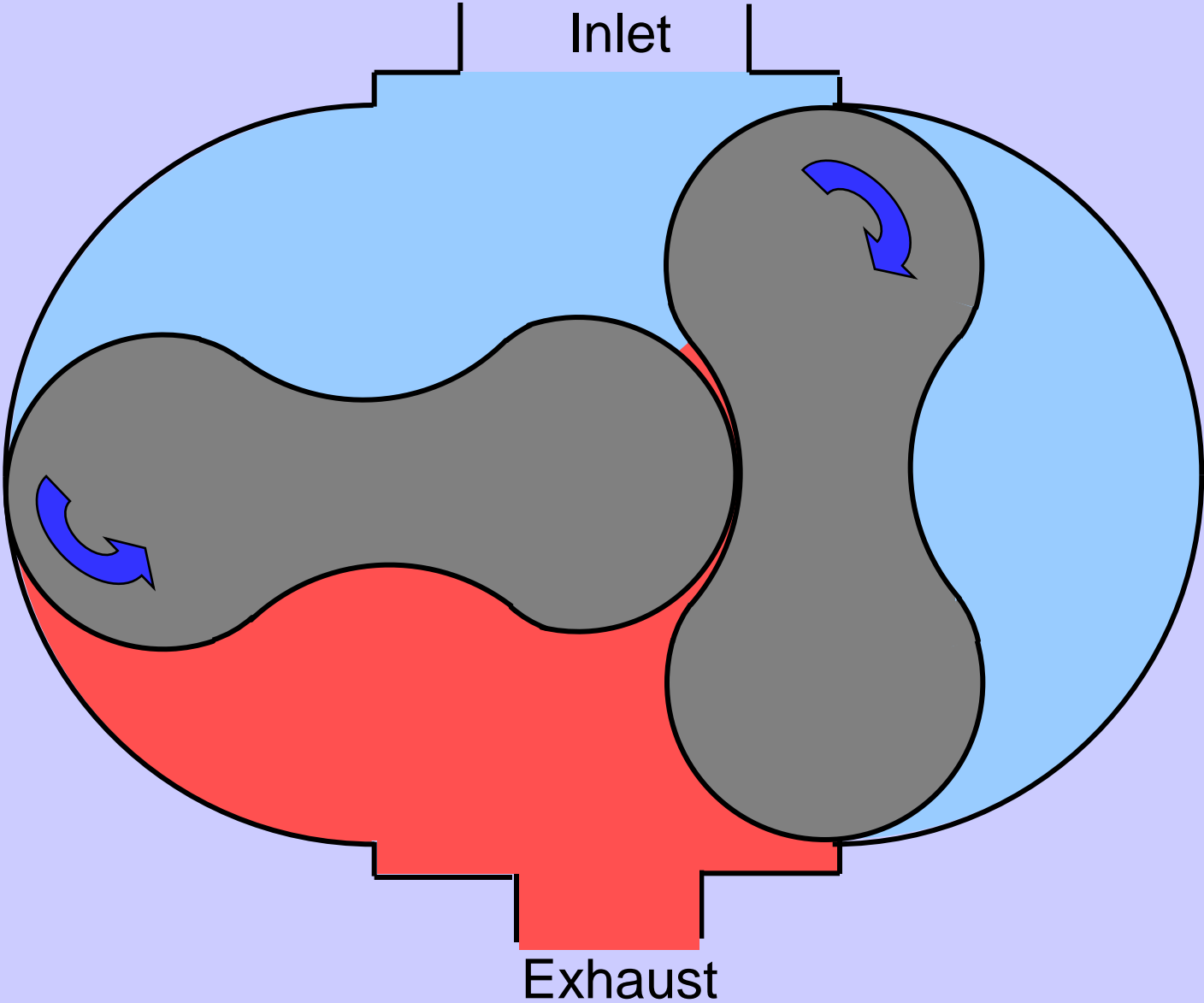

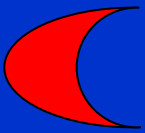

Roots Pumping Cycle

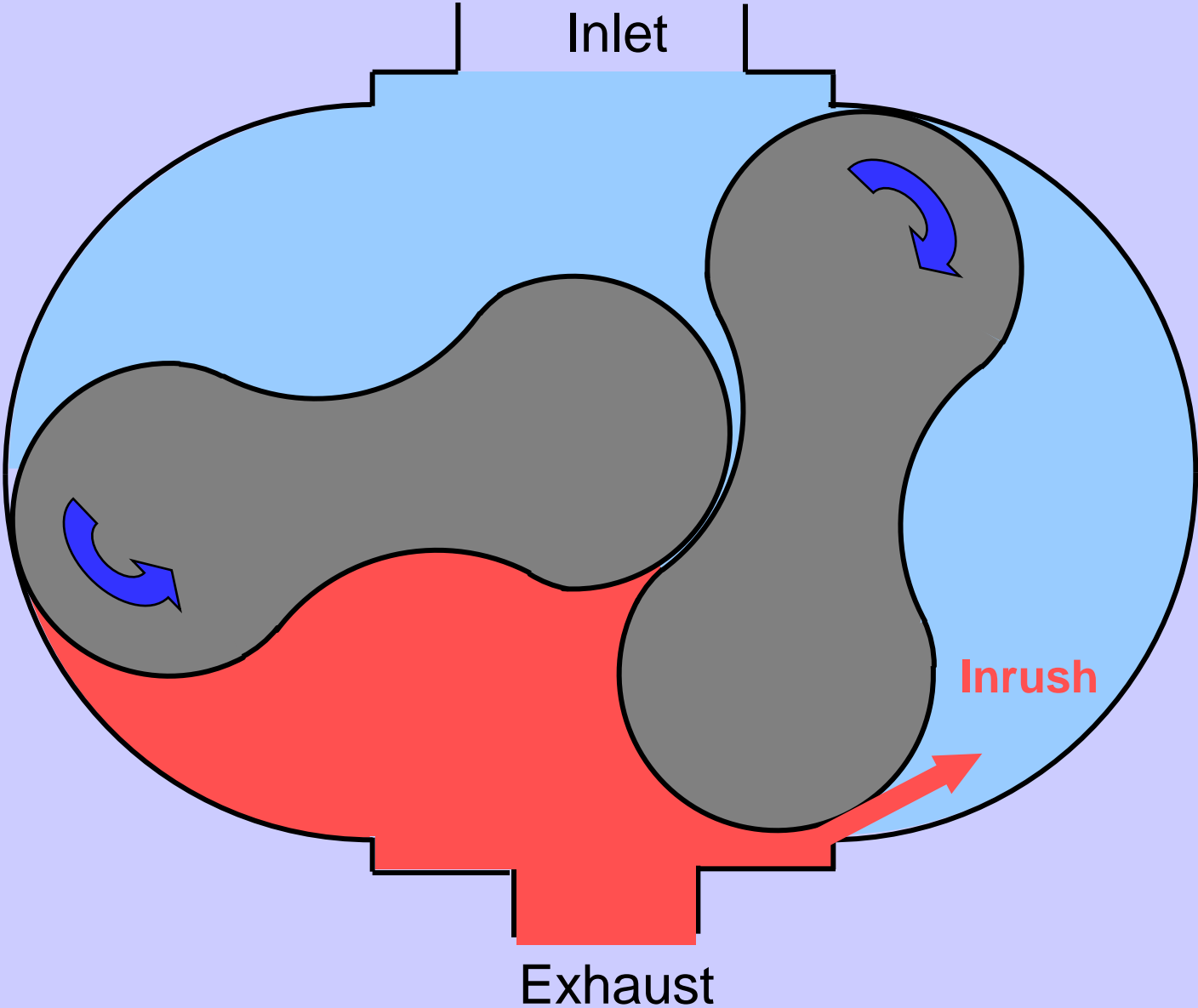

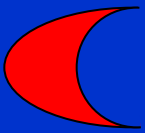

Roots performance

Roots No Flow Compression Ratio

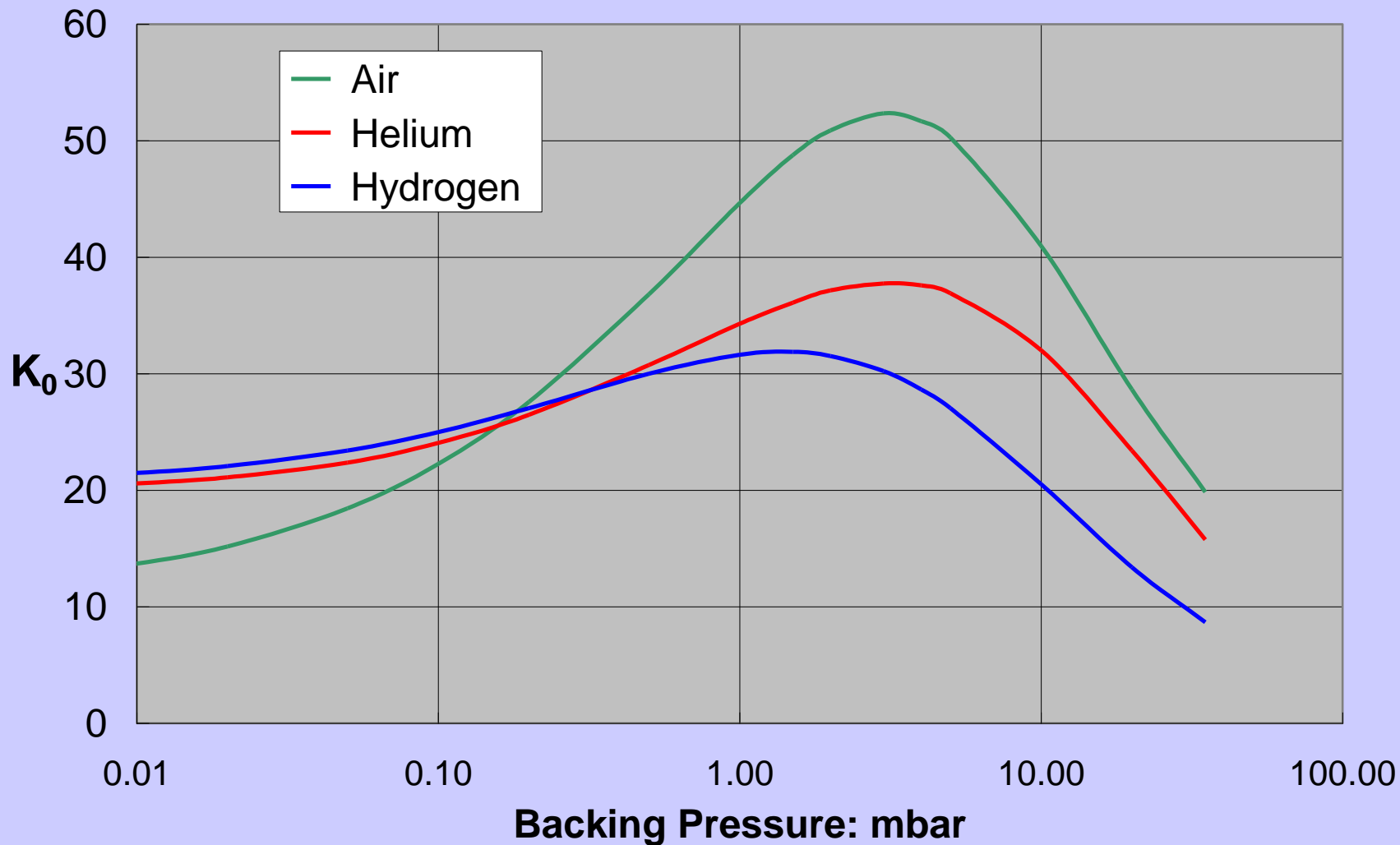

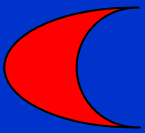

Root Trapping

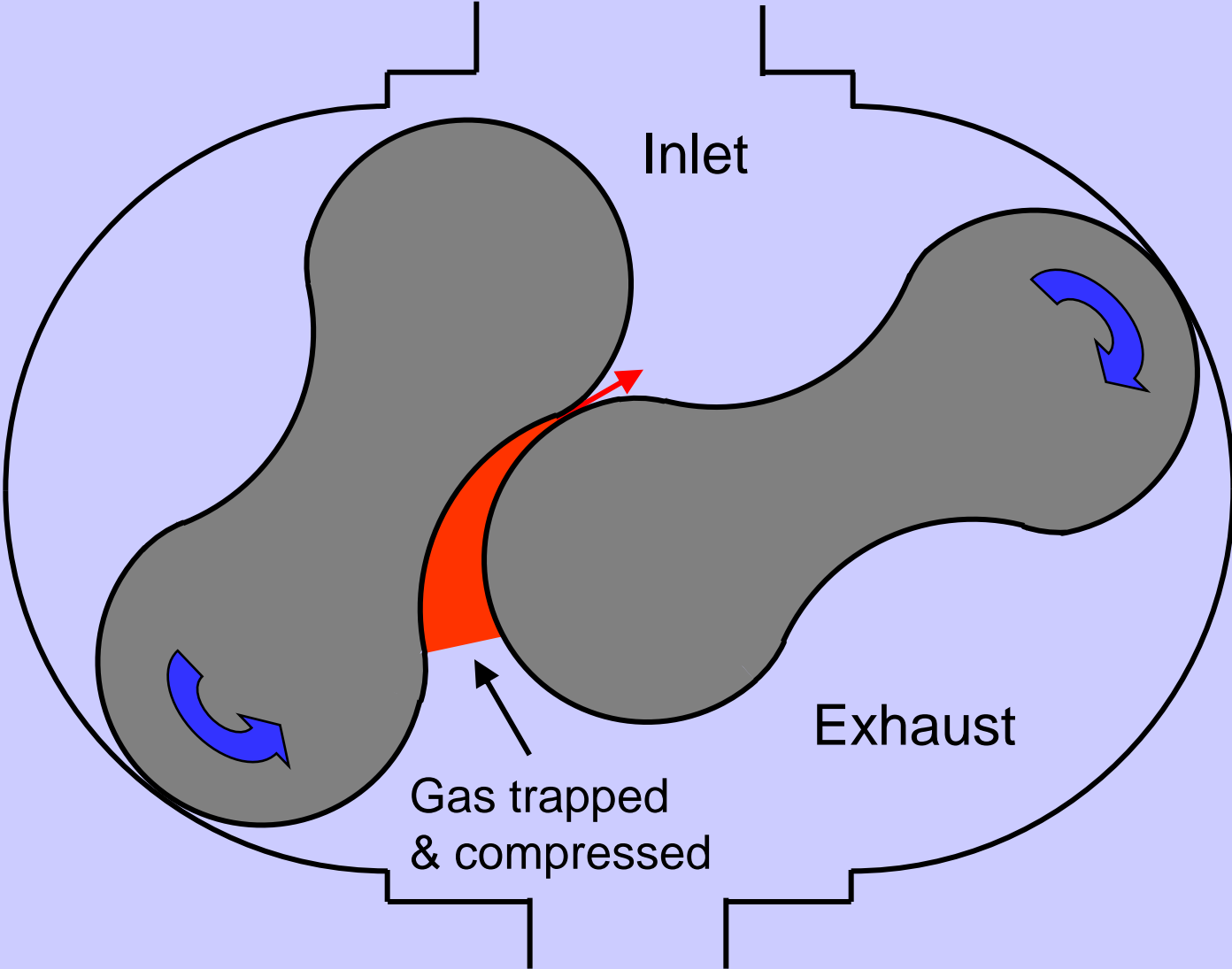

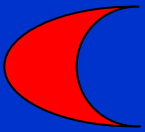

Effect of root trapping

Roots No Flow Compression Ratio

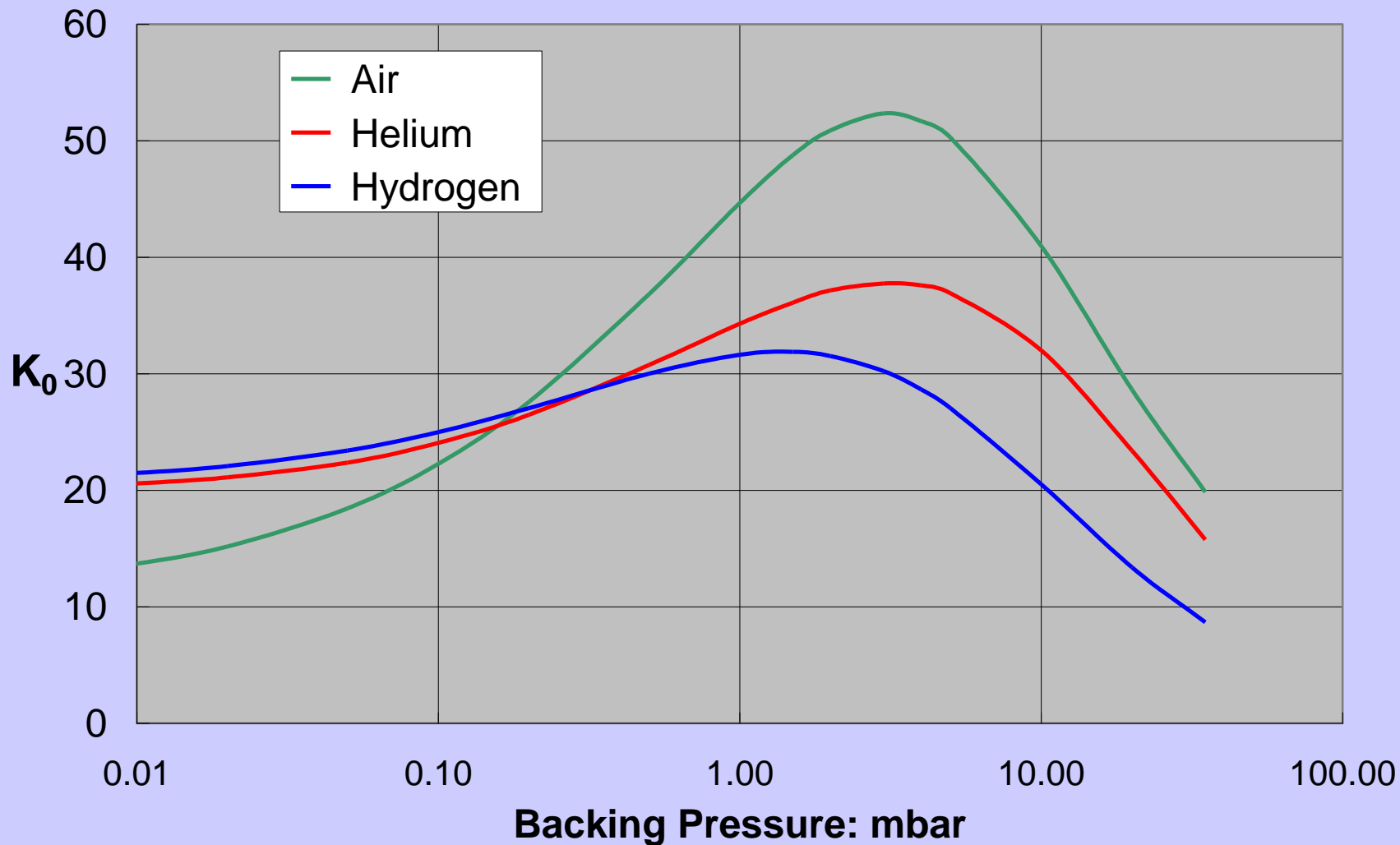

Single Stage Rootes

- Can be scaled to very large capacities
 - ~100 to 60,000 m³/h (750 rpm)
- Mainly used for boosting capacity of other primary pumps
 - Decreases ultimate by about 1 decade
- Can be used as primary pumps exhausting to atmosphere
 - $\leq 2:1$ compression ratio
- Tolerant of solid material
 - Straight through path

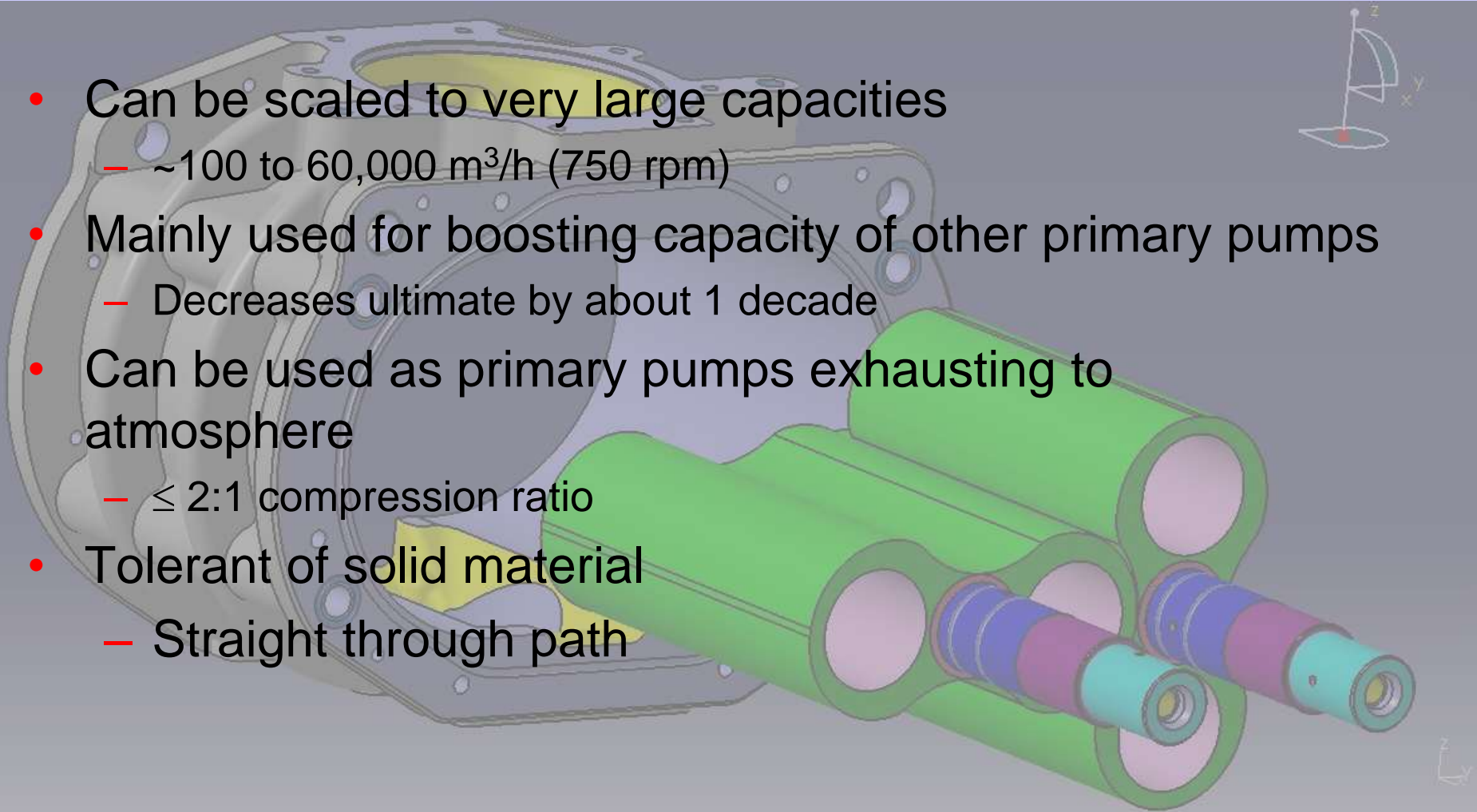

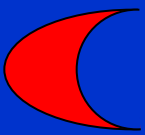

Single Stage Rootes

- Above ~ 1 mbar need some kind of protection to avoid excessive pressure difference & overheating
 - Bypass valve (exhaust to inlet)
 - Fluid coupling
 - Inverter drive to motor
- Very high power when used as exhaustor
- Large fast machines require protection against large shock loads produced during LL cycle

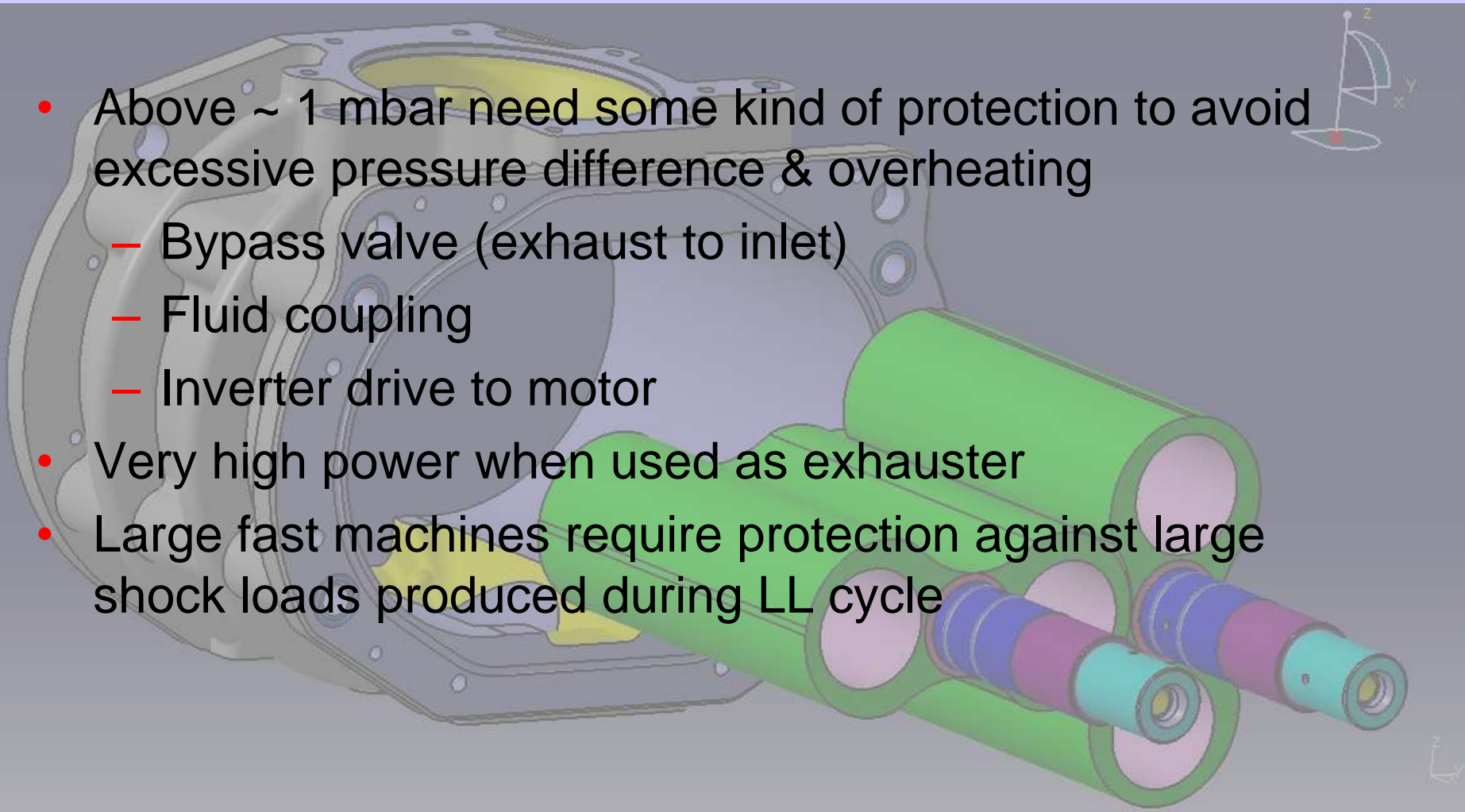

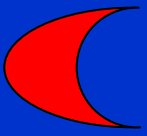

Multi-Stage Rootes

- Complete control over compression “trajectory”
 - via judicious selection of stage ratios
- Extended gas path can be used to assist thermal control
 - Interstage cooling
- Independent control of inlet and exhaust clearances
 - Relatively easy to produce small capacity / low power outlet stages
- Can be scaled up to moderately large capacities



Multi-Stage Rootes

- Relatively long ducting between stages can lead to condensation, corrosion
- Extended gas path can be difficult to transport solid material through
 - May get accumulations
- Abrupt compression
 - Exhaust gas re-expands into mechanism at each stage
- Tolerance build up across stages increases clearance at one end of pump (usually inlet)



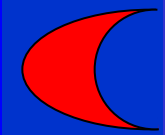

Exhaust Cooling

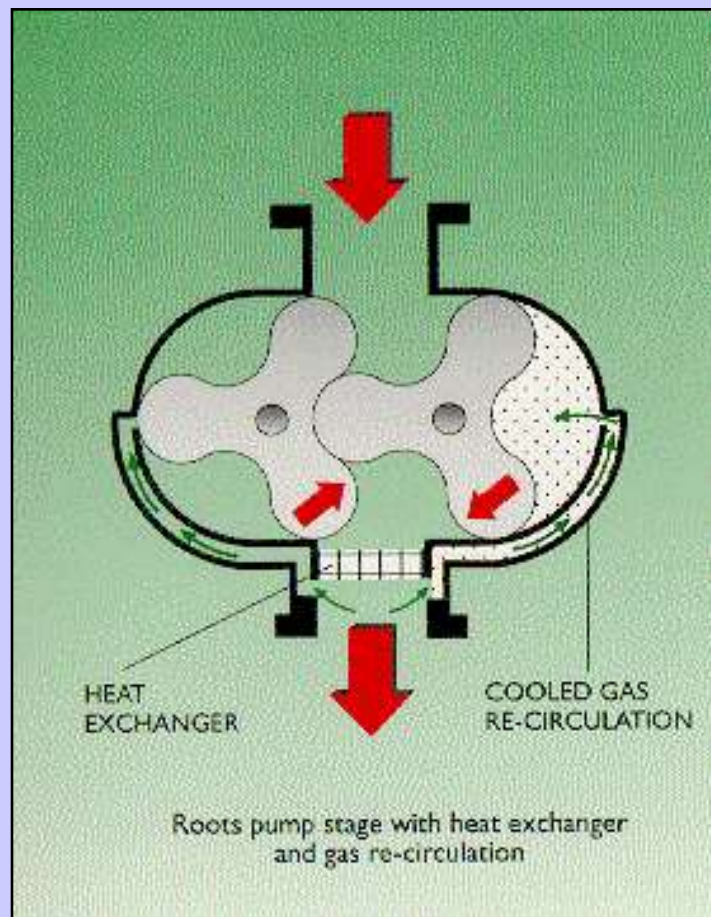

Dry Pump Technologies

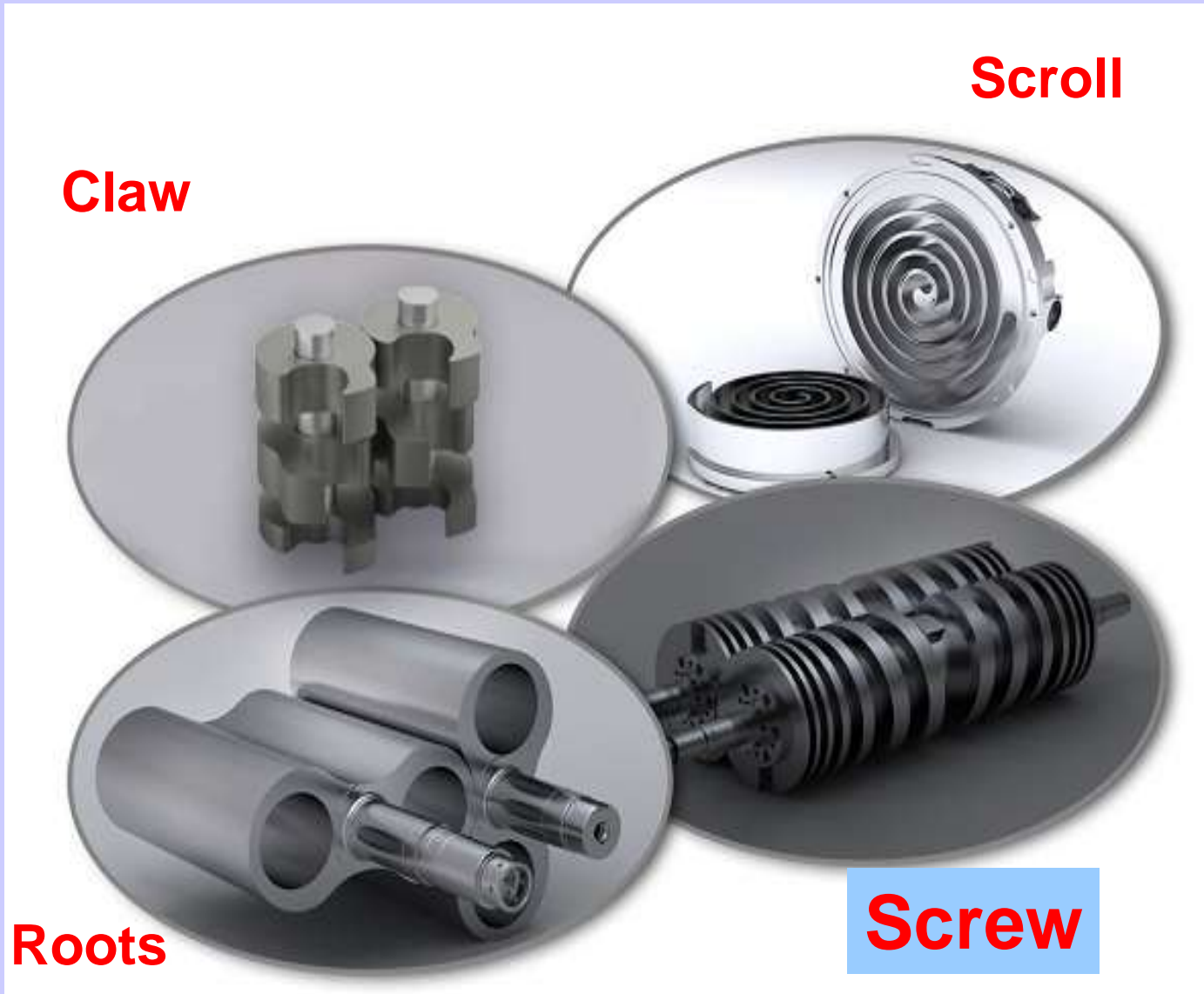

Screw Mechanism

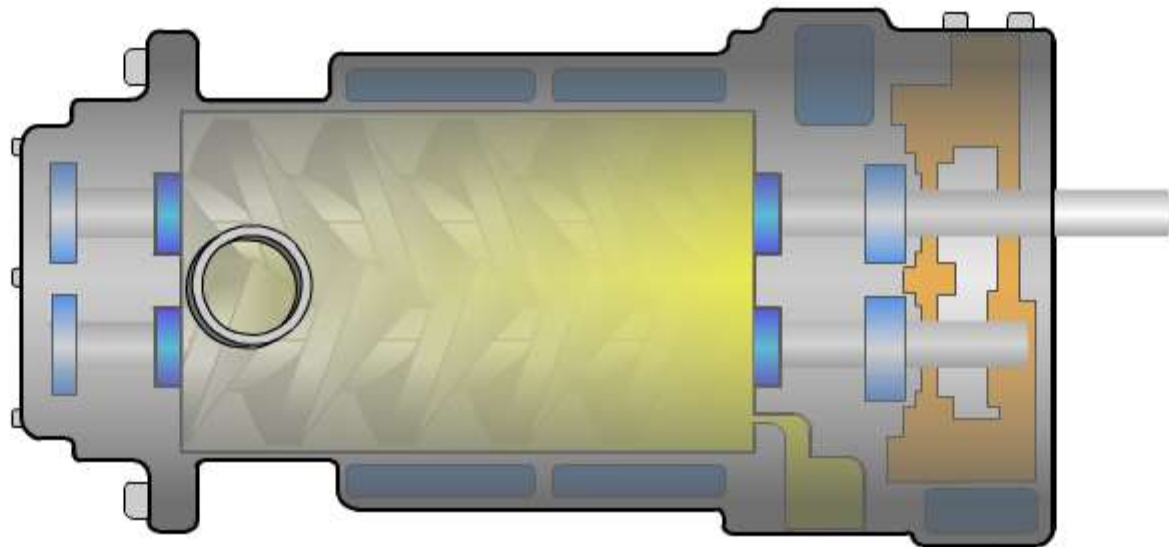

Comprises opposing synchronously rotating screws

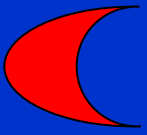

Screw

- Excellent handling of solid material
- Progressive compression
 - With tapers, variable pitch etc.
 - No sudden re-expansion until final exhaust port
- Compression “trajectory” can be designed
- Can be scaled up to moderately large capacities
- Tip clearance critical to overall performance
 - Direct “line of sight” from outlet to inlet
 - Performance can depend on “history” (temperature, flow)
- Clearances controlled at “whole pump level”
- More difficult to make small capacity machines / machines with small exhaust stages?

Screw Generation Technologies

Screw Generations

- Third generation

- Square screw form

- Easier to machine on mill turn using standard end mills
 - Gradual compression
 - No porting
 - No valve plate
 - Excellent dust and liquid



3rd Generation
"Square Cut Screw" with NO compression plate.



Leybold 3rd Generation No gas or water. Cheap, innovative but not for exhaust

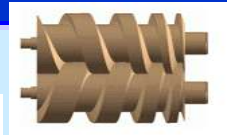

Edwards CDX 3rd Generation Screw. Parallel variable pitch square screws, no compression plate, indirect cooling



3rd Generation "Square Cut Screw" Semi 'S' series only

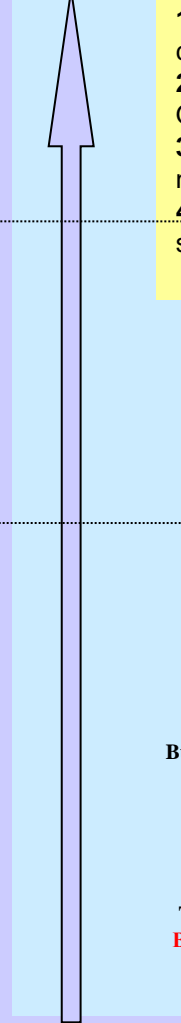

TC Range with Variable Pitch



2nd Generation Variable Pitch developed as KDPH range



Kinney factored Korean manufactured Kowel KDPH series as the NDV range



Rietschle factors Kowel KDPH series as Twister VSB range



Busch factors Taiko pump as Cobra AC range



NC Range developed

Nash believed to be factoring Busch NC range



Kinney factored Korean manufactured Kowel KDP Reciprocal agreement see Kowel factor Kinney LRP's



Rietschle factors Kowel KDP series as Twister VSA Range



Taiko Develops "Queen Bee" or "Quimby" screw profile pump



Failure to register patents in Korea leads to Kowel copies (KDP Range)

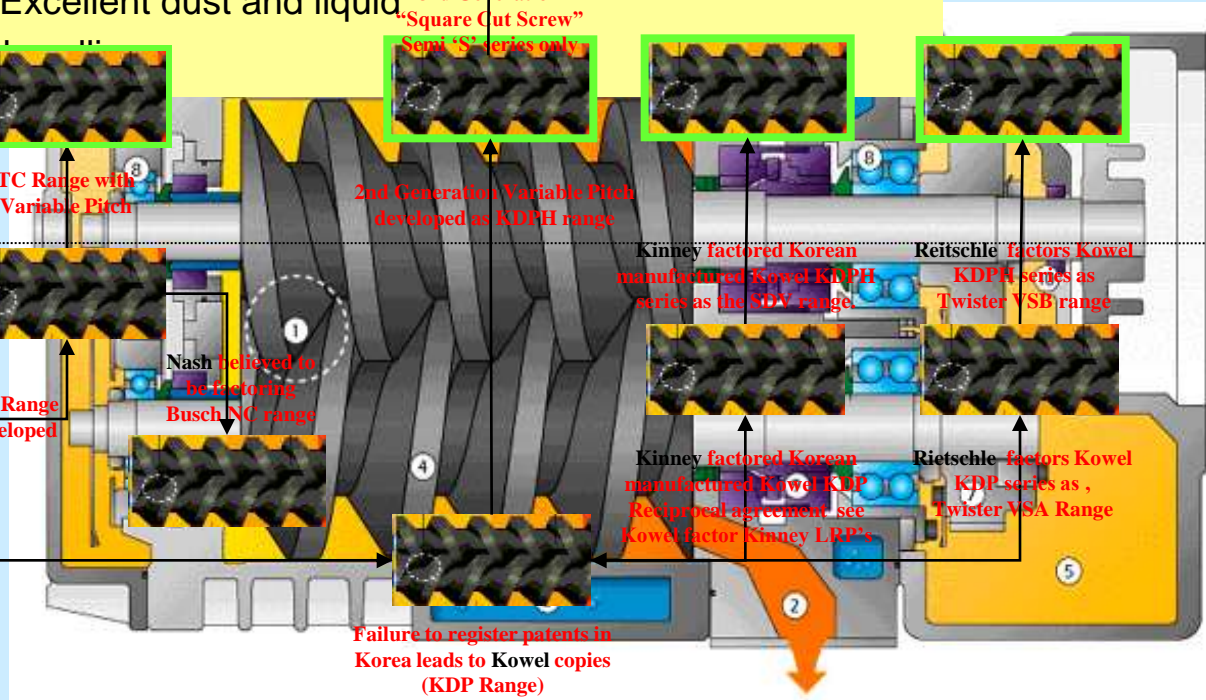

Square Screw Design

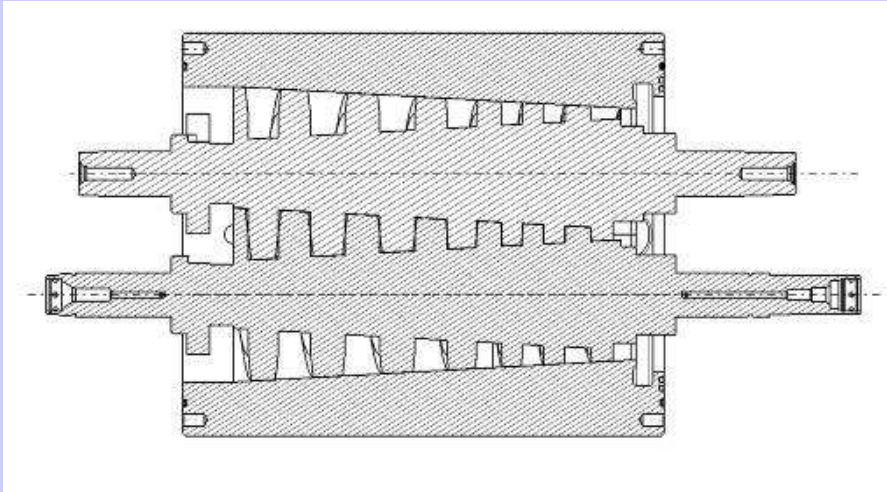

- Stepped changes of pitch – don't blend into each other so harder to manufacture
- Tapered design
- Discrete variable pitch for good thermal control
- Tip leakage limits pitch & hence swept volume – compromises light gas performance



Tapered Quimby

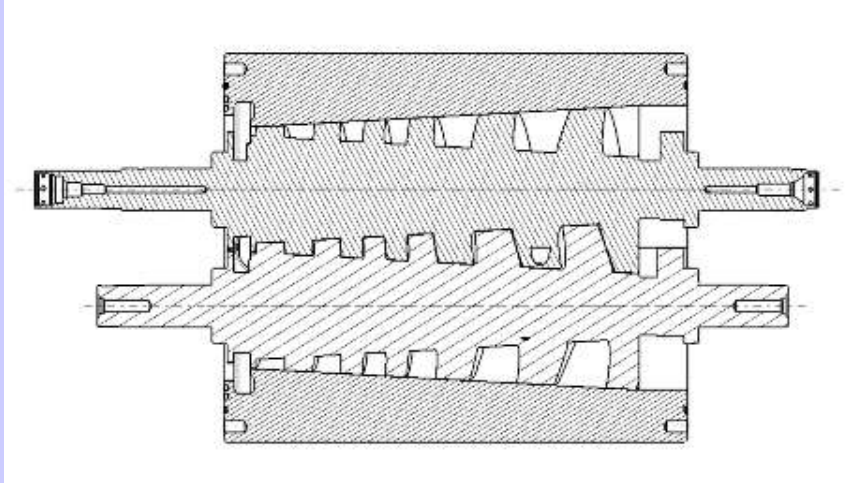

- No limit to the length of pitch
- Greater throughput can be achieved using Quimby screw in the same stator as a square screw
- Conjugate screw form – good sealing hence relatively good light gas performance
- ‘Discrete variable pitch for good thermal control
- More expensive to manufacture than square form

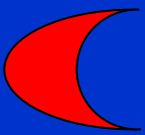

Screw Machines

Screws

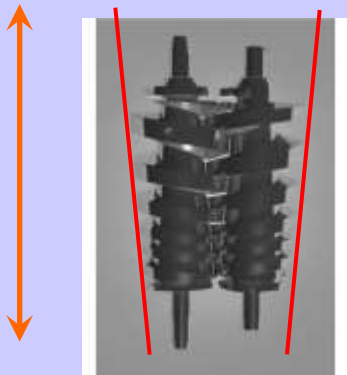

Tapered screws for tight clearances without coatings.

Screws not matched pairs

Tapered Screws

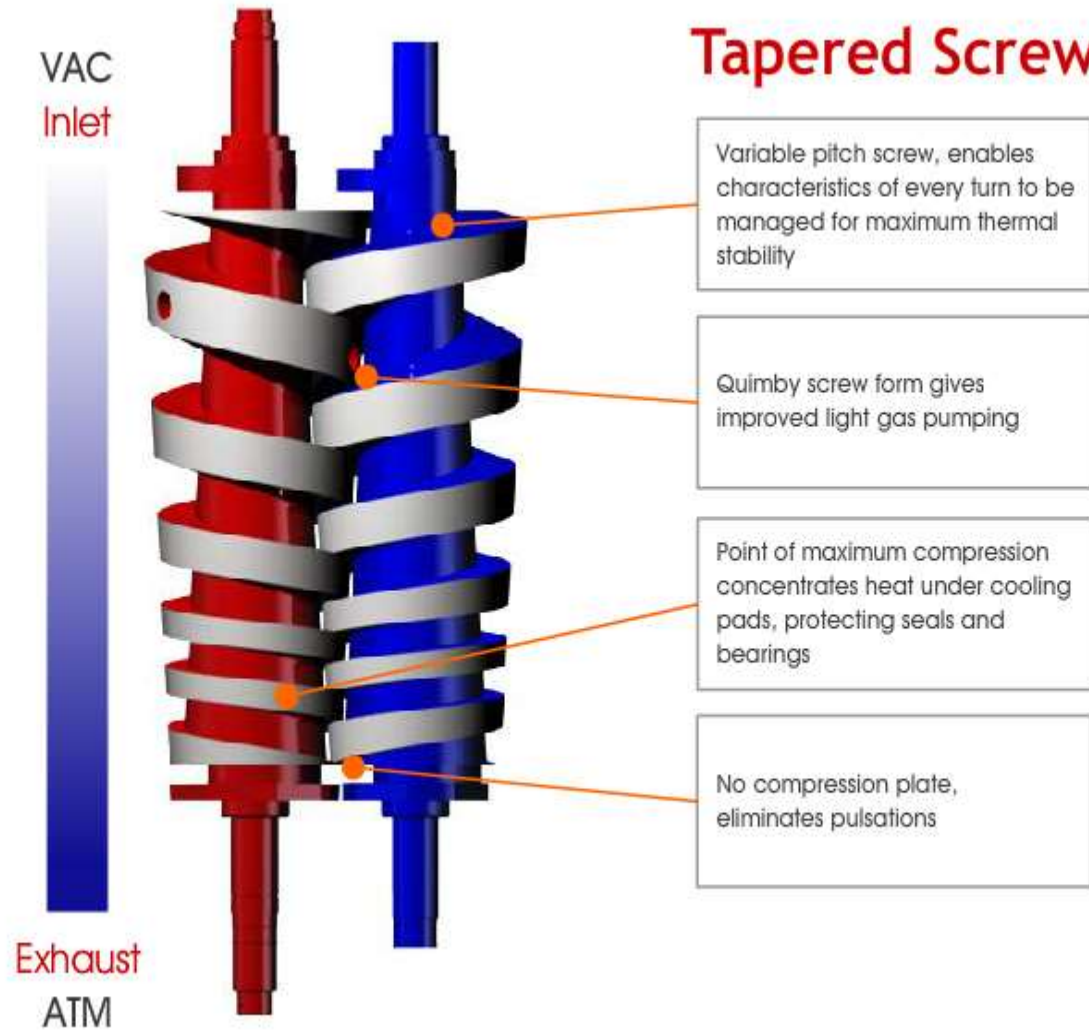



Finally

- Thanks to Edwards for information and illustrations
- However, presentation and any errors or omissions are entirely my responsibility